

MODULE-1**INTRODUCTION & BASIC MATERIALS USED IN FOUNDRY****Introduction**

Manufacturing is a process of converting raw materials into finished product. It includes design and manufacturing of goods using various production methods and techniques. The above figure illustrates the manufacturing process. Every product requires material from which the product is made and also requires a method to convert raw material into desired product. We need machines to convert the materials to get desired shape and size. To convert the raw material into the product using machine and methods we require men to operate the machines and to apply the methods. Money is the essential input required for purchasing raw materials, machines and man power.

Classification of manufacturing process:

- a. Casting
- b. Forming
- c. Machining
- d. Joining

a. Casting:

In casting process, the molten metal is poured into a mould cavity and is allowed to solidify after solidification, the casting is removed from the mould and cleaned, finally machined to the required shape and size and inspected before use. They are further classified into 2 types

1. Expandable mould
2. Permanent mould

1. Expandable mould

Here, the mould is prepared from sand, plaster or any other similar material which can break easily to remove the solidified part, in other words a new mould has to be prepared for each new casting. Eg: Green sand, dry sand, plaster, etc.

2. Permanent mould

Here, the mould is fabricated out of steel and can be used repeatedly to produce many castings. Eg: Gravity die casting, continuous casting, pressure die casting, centrifugal casting.

b. Forming

In forming process, the desired shape and size are obtained through the plastic deformation of material. The type of loading may be tensile, compressive, shearing or combination of these loads, unlike machining technique. In this process no material is removed and wasted.

1. Hot working

In this process deformation of metal takes place above its re-crystallization temperature.

Eg: Forging, rolling, extrusion, etc.

2. Cold working

In this process deformation of metal takes place below its re-crystallization temperature.

Eg: Bending, wire drawing, etc.

c. Machining process

The process of removing the unwanted material from a given work piece to give it to a required shape and size is known as machining. The unwanted material is removed in the form of chips from the blank material by a harder tool, so as to obtain a final desired shape.

1. Traditional or conventional machine

In this process a cutting tool is used to remove excess material from the work piece. The tool is rigidly mounted on the machine. Eg: Turning, milling, drilling, grinding, etc.

2. Non-Traditional or non-conventional machine

In this process, a layer of electron beam, chemical erosion, electric discharge and electro chemical energy is used instead of traditional cutting tool.

d. Joining

In this process, two or more pieces are joined together to produce the required shape and size of the product. The joint can be either permanent or temporary.

1. Permanent joint

In this joining, it can be done by pouring metals together i.e. welding, gas welding, etc.

2. Temporary joint

In this, it can be done by nuts, bolts, screws, adhesive (gum) bonding, soldering, brazing, etc.

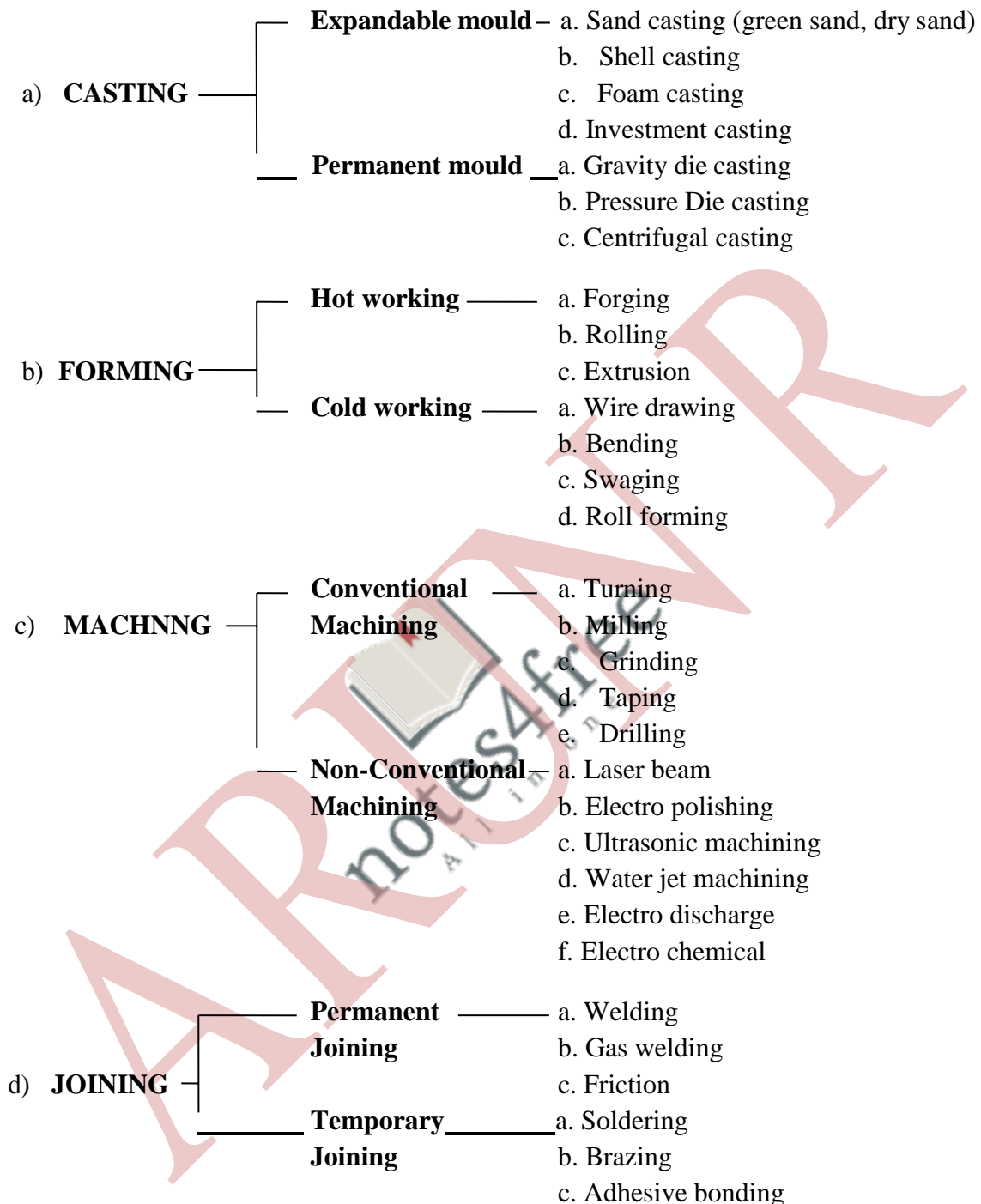
Schematic representation of the classification of manufacturing process.**Selection of a process for production**

Selection of a particular process for manufacturing to produce a given component depends on several factors. Some of the important factors to be considered are:

1. Shape to be produced
2. Quantity to be produced
3. Type of material
4. Surface finish and dimensional tolerance
5. Technical viability of the process
6. Economic consideration

1. Shape to be produced

The shape of the component plays a very important role in selection of the process. If the shape is simple it can be machined from raw material or it can be forged or extruded. However, when the shape is highly complex and intricate, casting is best suited.

2. Quantity to be produced

The quantity required is also an important factor for small quantities. Casting may not be required or economical, while for large quantities it is best suited.

3. Type of material

The type of material and its properties such as ductile, hardness, toughness, brittleness, are the contributing factors. Very hard materials cannot be machined easily. Brittle materials cannot be mechanically worked.

4. Surface finish and dimensional tolerance

The surface finish and dimensional tolerance limits the selection of process considerably. Eg: Commercial sand casting processes cannot be used for high degree of surface finish and tolerance are required, if they are used. Machining may become mandatory otherwise one has to use die casting or investment casting to overcome this problem. Similarly hot working may not give good surface finish and dimensional tolerance. It should be definitely followed by cold working finishing operation.

5. Quality and property requirement

A defect free product with a specific property serves its purpose for long life. Properties of cast materials are generally used when compared to that of mechanically worked materials, also castings give a lot of defects, hence a process that gives better property and quantity should be selected.

6. Technical viability of the process

The process selected must be technically viable i.e. we should be in a position to manufacture the components using this process without much difficulty.

7. Economic consideration

Customers often demand for product with more features and performance at reduced price, hence a low cost production process should be selected, but at the same time see that no compromise is made in terms of *quality*.

INTRODUCTION TO CASTING

In this process, components are produced by pouring molten metal into a contoured cavity followed by cooling to a solid mass.

1. The cold solid mass represents the configuration of the cavity and is the required shape of the component.
2. The components thus produced are called as **casting**.
3. The cavity compound to shape of the component is called **mould**.
4. The mould can be made of refractory material or metal.
5. The mould made out of refractory material is called **sand moulds** and that of made out of metal is called **metal moulds or dies**.
6. Cooling of liquid metal to solid metal is termed as **phase transformation**. The place where this activity is carried out is referred to as **foundry**.
7. In short, casting process involves shaping of the metal by using a mould cavity and hot metal.
8. In this process, the final shape is realized without using any other mechanism unlike in other processes, except the conversion of liquid metal to solid metal.

Steps involved in making a casting

1. Pattern
2. Mould preparation
3. Core making
4. Melting and pouring
5. Cleaning and Inspection

1. Pattern

A pattern is a replica of the object is to be cast. It is used to prepare a cavity into which the molten metal is poured. A skilled pattern maker prepares the pattern using wood, metal, plastic or any other material. Many factors like durability, allowance for shrinkage and machining, etc., are considered when making a pattern.

2. Mould preparation

It involves for making a cavity by packing sand around a pattern enclosed in a supporting metallic frame. When the pattern is removed from the mould an exact shaped cavity remains into which the molten metal is poured. Gating and risering are provided at suitable locations in the mould.

3. Core making

In some cases a hole or a cavity is required in the casting. This is obtained by placing a core in the mould cavity. The shape of the core corresponds to the shape of the hole required. The mould is cleaned & finished before metal pouring.

4. Melting and pouring

Metals or alloys of the required composition are melted in a furnace and poured in to the mould cavity. Many factors like temperature of molten metal, pouring time, turbulence, etc should be considered while making & pouring.

5. Cleaning and Inspection

After the molten metal is solidified and cooled, the rough casting is removed from the mould, cleaned and dressed (removing cores, adhered sand particles, gating, risering system, fins, blisters, etc from the casting surface) and then sent for inspection to check for dimensions or defects like blow holes, crakes, etc.

Procedure for making a casting

a. Mould box

It is usually a metallic frame used for making for holding a sand mould. The mould box has two parts. The upper part is called “Cope” and the lower part is called “Drag”.

b. Parting line

It is the zone of separation between a cope & drag position of the mould in sand casting.

c. Sprue/Runner

It is a vertical passage through which the molten metal will enter the gate.

d. Pouring basin

The enlarge position of the sprue with its top into which the molten metal is poured.

e. Gate

It is a short passage way which carries the molten metal from the runner sprue in to the mould cavity.

f. Riser

A riser or a feed head is a vertical passage that stores the molten metal and supplies the same to the casting as it solidifies.

g. Mould cavity

The space in a mould that is filled with molten metal to form the casting upon solidification.

h. Core

A core is performed by using a mass of sand placed in the mould cavity to form hollow cavity in the castings.

i. Core print

It is a projection attached to the pattern to help for support and correct location of core in the mould cavity.

FLOW CHART INDICATING THE STEPS IN A CASTING

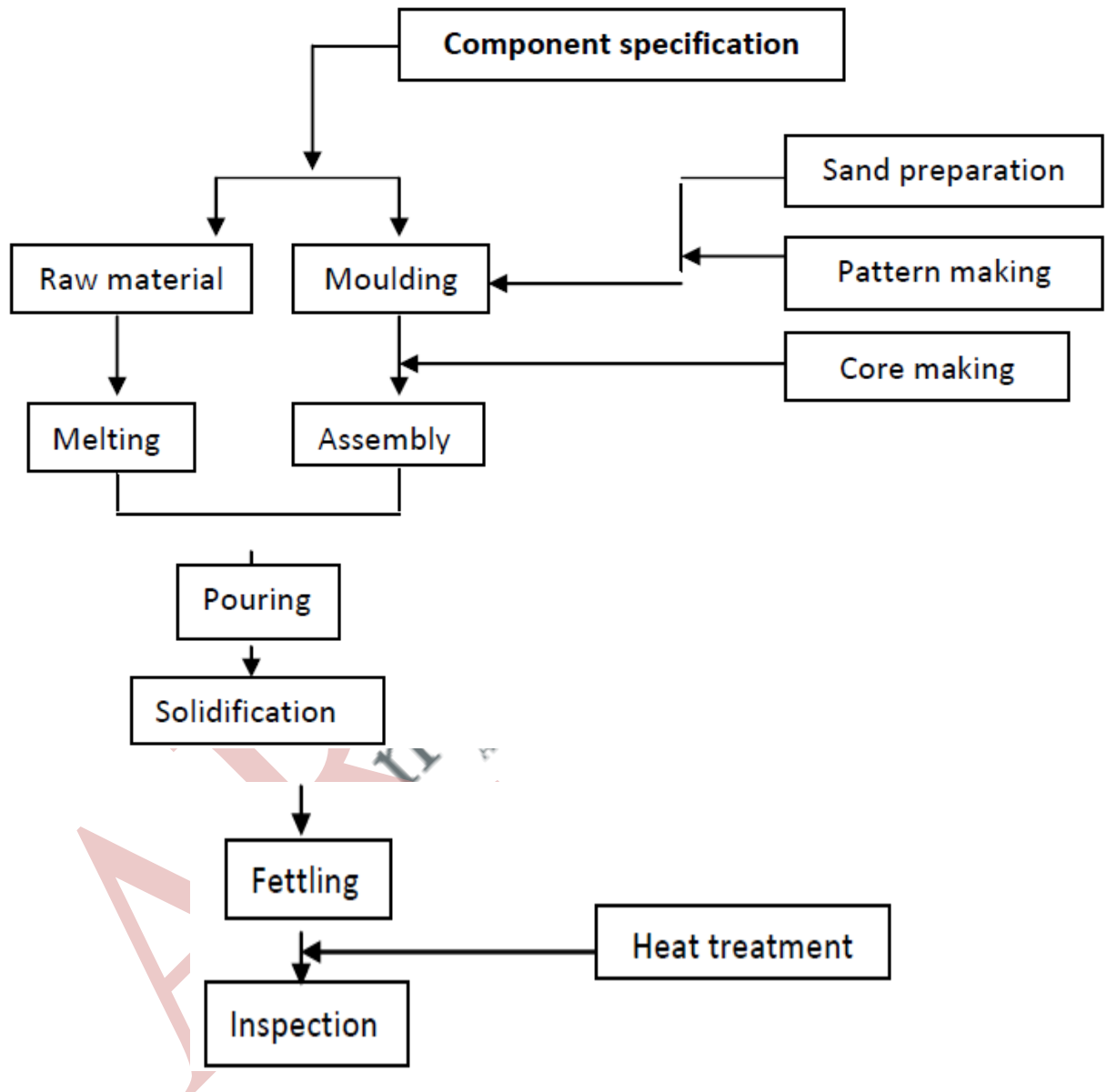

Varieties of Components produced by casting process

- Casting is the 1st step and the primary process for shaping any material. All materials have to be cast before it is put in use.
- The ingots produced by casting process are used as raw material for secondary processes like machining, forging, rolling, etc.
- To list the components produced by casting is an endless process, a few major components produce by casting are given below:
 - a. **Automotive sector:** A few parts like brake drum, cylinder, cylinder linings, pistons, engine blocks, universal joints, rocker arms, brackets, etc.
 - b. **Aircraft:** Turbine blades, casting, etc.
 - c. **Marine:** Propeller blades
 - d. **Machining:** Cutting tools, machine beds, wheels and pulleys, blocks, table for supports, etc.
 - e. **Agriculture & rail road equipments:** Pumps and compressor, frames, valves, pipes and fittings for construction.
 - f. Camera frame, parts in washing machine, refrigerator & air-conditioners
 - g. Steel utensil & a wide variety of products.

Advantages and limitations of casting process

Following are a few advantages and limitations of casting process.

Advantages:

- Casting is the basic and versatile (flexible) manufacturing process.
- Difficult shapes can be easily cast.
- Large, hollow & intricate shapes can be easily cast.
- Casting provides freedom of design with respect to shape, size and quality of the product.
- Some metals that cannot be machined can be produced by casting to the required shape.
- Heavy objects can be produced only by casting process.
- Controlled mechanical & metallurgical properties can be obtained.
- Casting process is most suitable for mass production.
- A large variety of alloying composition & properties can be obtained.
- Directional properties can be obtained in certain cases by controlled cooling.
- Parts with close dimensional tolerance & ready to use can be produced by special casting methods.

Disadvantages OR Limitations

- ✓ Casting process is an elaborate process and involves operations.
- ✓ It requires large infrastructure like casting section, melting, pattern, core section, cleaning, finishing, and inspection.
- ✓ Very high investment is required.
- ✓ Casting process is not economical & viable for small scale operations.
- ✓ The man power requirement is large.
- ✓ High care is required in handling chemicals and molten metal.
- ✓ The actual casting operation cannot be automated.
- ✓ Generally most operations may be casting or one of type i.e. mould has to be prepared for each casting.
- ✓ Great care is required in controlling the cooling rate to obtain defect free casting.
- ✓ Very difficult to cast thin sections.

PATTERNS:

Definition: Pattern is a tool used to produce the mould cavity. It is a mould making tool. The shape of the pattern is the same as that of the component or casting, but the size will be slightly larger than the casting. Pattern is also referred to as the positive replica of the casting. A number of castings can be made using a single pattern.

Functions of a pattern: The basic functions of a pattern are;

- To produce the mould cavity faithfully.
- To establish parting line.
- To promote production of quality casting
- To incorporate gating system and riser.
- To bring economy to the process.
- To have provision for core prints.

Materials used for Patterns: Before selecting a particular material, a few factors are to be considered, they are:

- a) Number of castings to be produced.
- b) Degree of accuracy and surface finish of casting required.
- c) Shape and size of the casting.
- d) Re-usability of pattern, so that they will provide a repeatable dimensionally acceptable.
- e) Type of mould material used- clay or resin.
- f) Type of moulding selected – green sand moulding, investment process etc.

The following materials are used for making patterns:-

- a) **Wood** – Well seasoned teak wood is used for the pattern. Wood is soft, light and easy to work and takes the shape easily. Used for producing smaller number of castings. Large and small patterns can be made. It wears out faster, cannot withstand rough handling and can absorb moisture.
- b) **Metal** – Is stronger than wood, but heavier than wood. Can maintain dimensions accurately for a very long time. Does not absorb moisture. Used to produce large number of castings. Has longer life. It is difficult to repair. Bigger sized patterns cannot be made using this.
- c) **Wax** – Is a low melting point material. Imparts good surface to the mould. Can be recovered and used again and again. Used in investment casting moulding. A combination of paraffin, wax, bees wax, etc. is used for making the pattern.
- d) **Plastics** – Plastic material is a compromise between wood and metal. Thermosetting resins like phenolic resin, epoxy resin, foam plastic etc. are used as materials for making pattern. It is strong and light in weight. Does not absorb moisture during its use and storage. Gives good surface finish to castings. Thin sections are difficult to cast using plastics. Initially plastic patterns have to be cast and finished to desired shape and size. This leads to the increase in cost of the final cast product.
- e) **Plaster** – Gypsum or plaster of Paris is another pattern material capable of producing intricate castings to close dimensional tolerances. They are strong, light in weight, easily shaped, gives good surface finish. However, they used for small castings only. Plaster readily mixes with water and when allowed sets and becomes hard. Normally plaster is used for producing master dies and moulds.

Various Pattern allowances and their importance:

Pattern has the same shape as that of the casting but the dimensions will be generally more than that of the casting. This extra dimension from the required value, given on the pattern is called as “*allowances*”. These allowances need to be given on the pattern due to metallurgical and mechanical reasons. The different types of allowances are;

- a) Shrinkage allowance
 - b) Draft allowance
 - c) Machining allowance
 - d) Scale & Grinding allowance
 - e) Distortion allowance
- a) **Shrinkage allowance:** All metals and alloys undergo decrease in volume when cooled from liquid temperature to room temperature. This change in volume of metal or alloy is called as “*shrinkage*”. Fig. 1 shows the variation of shrinkage as a function of temperature. As the molten metal is cooled from its superheat temperature, the volume starts decreasing continuously till it reaches room temperature. This is a natural phenomenon. Shrinkage of metal or alloy takes place in three stages viz. liquid to liquid, liquid to solid and solid to solid. The first two are taken care of by providing risers in the castings. The last one is taken care of by providing shrinkage allowance on the pattern.

This is also referred to as pattern shrinkage allowance. The value of this depends on the nature of the metal or alloy. This allowance when given on to the pattern, will increase its size. Pattern maker's scale is available to facilitate easy and direct measurement. Pattern shrinkage for some metals is:

| | | |
|------------|------------|-------------------------|
| Ex. | Cast steel | 3-5 mm per 100mm length |
| | Aluminium | 3-4 mm per 100mm length |
| | Cast iron | 2-3 mm per 100mm length |

Shrinkage Allowance

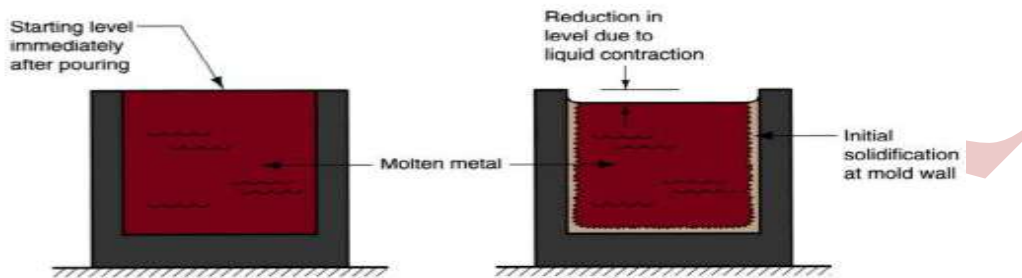

b) **Draft allowance:** It is the allowance given to the vertical surface of the pattern to facilitate easy removal of the pattern from the mould cavity, without causing any damage to the mould. This allowance depends on the type of moulding. Fig. 2 and 2a, 2b & 2c shows the method of draft allowance given in patterns. Damage is caused to the vertical pattern portions of the mold, when there is no draft. Hence by giving taper or draft on the vertical portions of the pattern there is no damage caused to the mould when the pattern is lifted upwards.

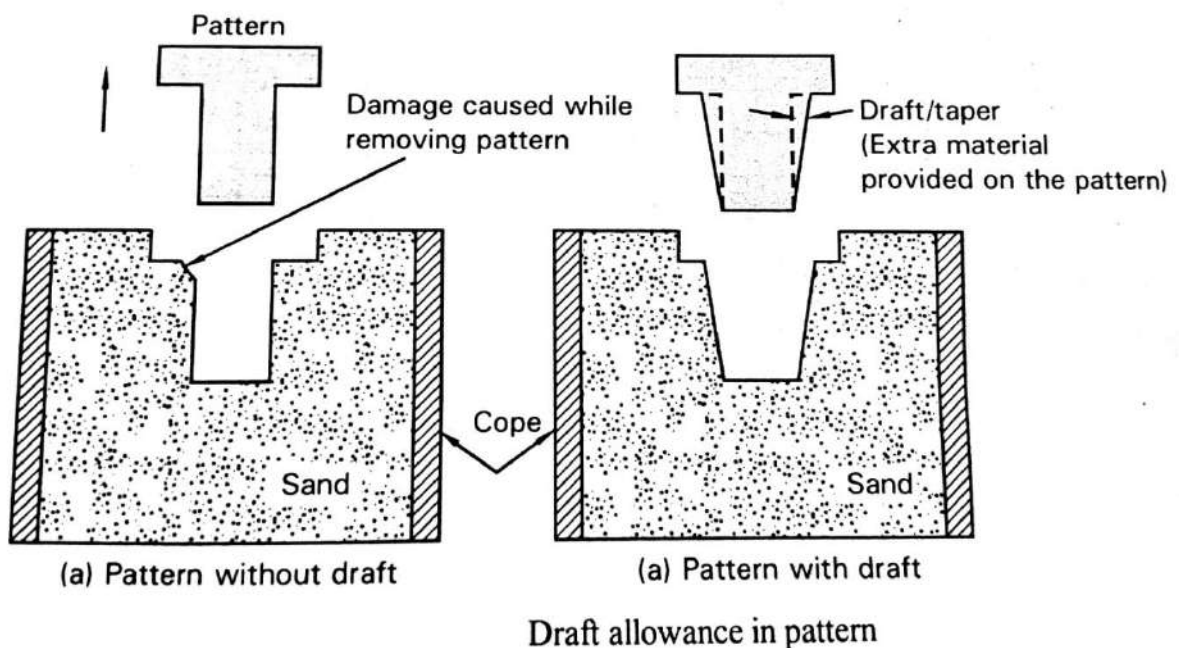

- c) **Machining allowance:** Most of the castings will have more than one surface that needs machining. The dimensions get reduced after machining. Hence, the size of the pattern is made larger than required. During machining, this extra material on the casting is removed. This allowance depends on the nature of the metal and the dimensions of the castings. Typical machining allowances are:

| | | |
|------------|--------------------|------------|
| Ex. | Cast Iron | 1-10 mm |
| | Cast steel | 3-12 mm |
| | Aluminium | 1.5-4.5 mm |
| | Alloys | 1.5-4.5 mm |
| | Brass, Bronze, etc | 1.5-5 mm |

- d) **Scale & Grinding allowance:** Most of the castings undergo heat treatment and due to higher temperatures scales are formed on the surface. This needs to be removed by grinding operation. In addition, sometimes surface roughness or imperfection needs to be removed by grinding operation. Hence, the size of the casting is made slightly bigger than the required to accommodate this. The magnitude of this extra allowance is 0.2 -3 mm.
- e) **Distortion allowance:** Casting having shapes such as C, U and large plate, lose their shapes during solidification. The loss of shape is referred to as *distortion*. This is due to the shrinkage stresses present during solidification. To take care of this, the pattern is given an allowance in the direction opposite to the expected distortion. This is referred to as *distortion allowance*. More or experience is essential in addition to the design knowledge in arriving to this allowance. Fig. shows the distortion allowance.

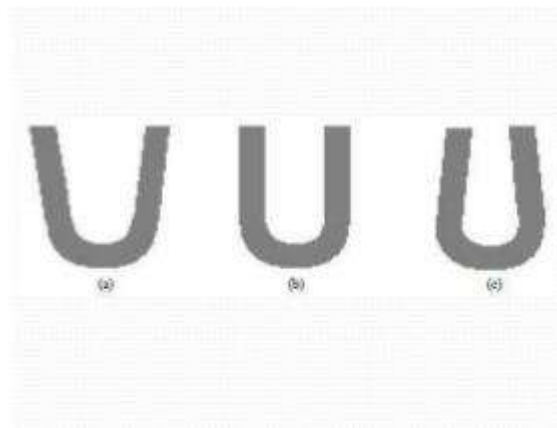
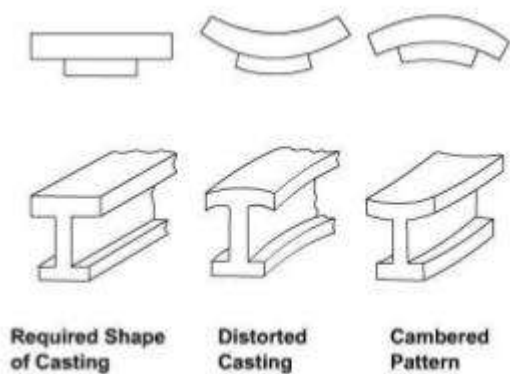

Classification of patterns: Patterns are of various types. But the selection of a particular type of pattern depends upon the type of moulding process employed, shape and size of the casting required. Some of the commonly used patterns are discussed.

- a) **Single piece pattern:** Single piece pattern also called, solid pattern the simplest type made in one piece without any joints or loose pieces. Used for simple shape and large size castings. It can be made easily. Fig. Shows the single piece pattern.

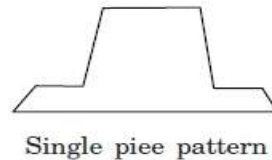

- b) **Split pattern:** Consists of pattern in two halves joined by a pin. It is used to prepare moulds using hand. It is used popularly in hand moulding. The split can be at two or more planes. The split in the pattern facilitates easy moulding. Fig. shows the split pattern.

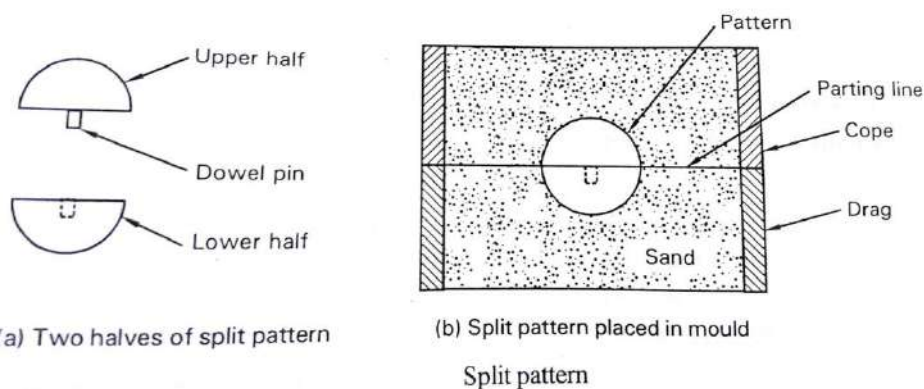

- c) **Loose piece pattern:** Pattern consists of a main body to which small projection pieces are attached. These pieces can be removed from the mould after removing the main body. This type of pattern is used to get undercut portions in the castings. Fig. shows the loose piece pattern.

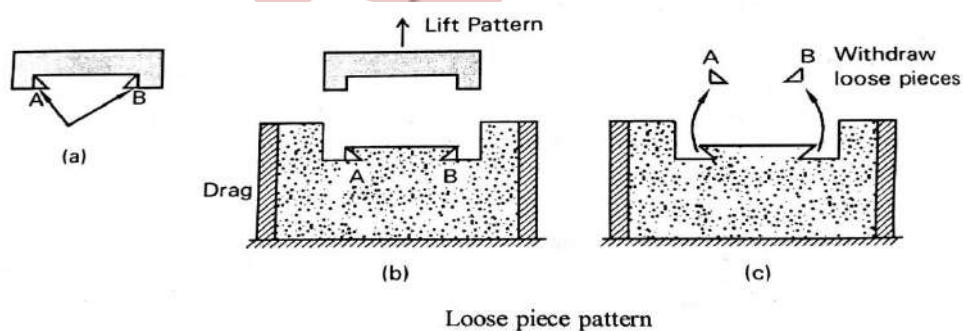

- d) **Cope & Drag pattern:** It is basically a two part pattern (split type). Each half is fixed to a metal plate separately with gates, runners and risers. These two plates with patterns are used to make moulds in a moulding machine, separately to get bottom and top mould cavities. The bottom portion is called as the drag portion and the top portion is called as the cope portion. Hence the names cope and drag pattern. The two moulds are prepared separately using separate machines and assembled. This type of pattern is used to produce large number of castings. Fig. Shows the cope & drag pattern.

- e) **Gated pattern:** This consists of a number of patterns attached with runner, ingate, sprue and risers. A cope & drag pattern may be used for this purpose. A machine is used for making the moulds. More number of castings can be produced per mould. Size of the casting is small. Fig shows the gated pattern.

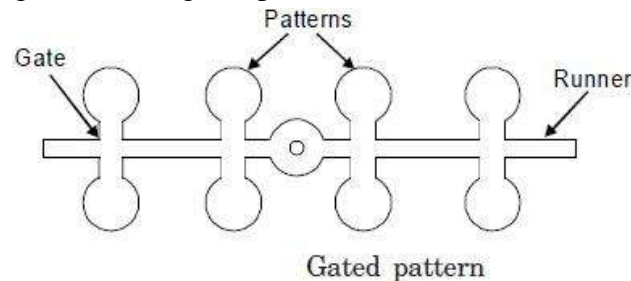

- f) **Match plate pattern:** This consists of two parts of the pattern mounted on either surfaces of a metal plate. It is basically a split pattern. The two parts are perfectly aligned. It is used in a moulding machine. Both cope and drag boxes are made in the same machine one after the other. When the two boxes are closed, the desired mould is obtained. Fig. shows the match plate pattern.

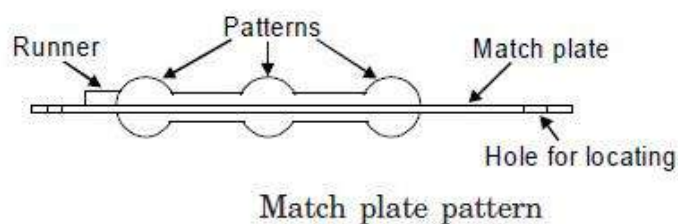

- g) **Follow board pattern:** When the shape of the pattern is such that it cannot be held stable in its position, a wooden board conforming to the contour of the pattern is used to rest the same in correct position and moulding is carried out. Such a pattern which needs a follow board is referred to as follow board pattern. Follow board holds the pattern till the moulding is over. Even for moulding thin sections follow board is used. Fig. shows the follow board pattern.

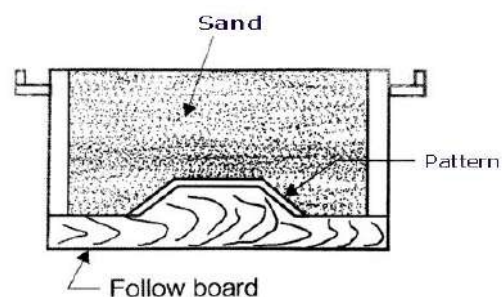

- h) **Skeleton pattern:** It consists of a number of wooden pieces assembled together to form the desired shape. The assembly resembles a skeleton. The skeleton portion is then covered with thin boards. This type of arrangement is used for heavy and big castings and the numbers

required is only a few. Material saving for the pattern is achieved and the cost of pattern is reduced. Used for simple shapes. Ex. Water pipe bends, frames, calve bodies can be cast. Fig. shows the Skeleton pattern.

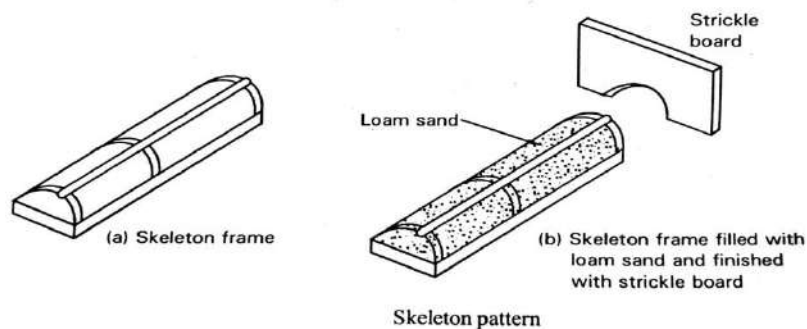

i) **Sweep pattern:** Makes use of a thin board of wood conforming to the outer contour of the casting. It is used when the casting has a surface of revolution contour such as cylindrical, bell shape, etc. Can be used for small or big castings and the number of castings is not a problem. Saves pattern material. It is easy to handle and store. It can be used for making cores. Fig. shows the sweep pattern.

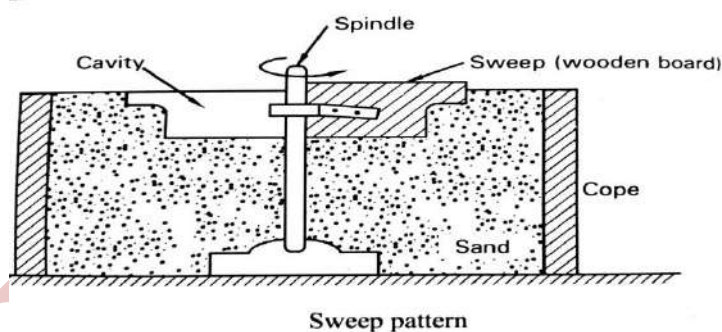

BIS color coding of Patterns: For easy recognition of different portions of the pattern, standard colour codes have been recommended for the finished wooden pattern. The standard colour code adopted by the American Foundry men's Society (AFS) is being used all over the world. Each colour conveys how the castings will be.

| Sl. No. | Colour | Casting position |
|---------|---|--|
| 1 | Black | Casting surface to be left unfinished |
| 2 | Red | Surface of casting to be machined |
| 3 | Red stripes on yellow background | Loose pieces & seats |
| 4 | Yellow | Core prints and seats for loose core prints |
| 5 | Diagonal black stripes on a yellow base | Stop offs (portions of a pattern that form a cavity which are filled with sand before pouring). They are reinforcements to prevent delicate portions of the pattern. |

Due to extensive use of metal and plastic patterns, the colour code is used less now a days.

BINDER: The sand used for preparing moulds is a mixture of *silica sand* (of all the various sand like zircon, olivine, magnesite etc., silica sand is the widely used), *binder* and *additives*.

Moulding sand = Silica sand + Binder + Additives

A hard mould is the primary requirement is making any castings, and binders serve the purpose. A binder is a material used to produce cohesion or bind the sand particles (silica sand) together thereby imparting strength to the sand. Clay binders (Bentonites) are the most widely used for bonding moulding sands. But, clay activates or tends to bind sand particles only in the presence of water (moisture). The amount of water added to clay should be based on experimental trials because, if too little water is added, the sand will lack strength as the bond between the sand is low. On the other hand, too much water causes sand to reach semi liquid state thereby making it unsuitable for moulding. In other words, for a given percentage of clay, there is an optimum percentage of water that gives favorable properties to the moulding sand. For good moulding sand, clay may vary in the range 6-12% and moisture from 3-5%.

Types of binders used in moulding sand: Binders are classified into two types:

- a) Organic binders and
- b) Inorganic binders.

Organic group of binders include:

- Dextrin – made from starch
- Molasses – a byproduct of sugar industry
- Cereal binders – gelatinized starch and gelatinized flour
- Linseed oil – a vegetable oil
- Resins – urea formaldehyde, phenol formaldehyde etc.

Inorganic group of binders include:

- Clay binders – bentonite, fire clay, etc
- Portland cement
- Sodium silicate etc.

ADDITIVES:

Additives are generally added to develop certain new properties, or to enhance the existing properties of the moulding sand. They do not form a compulsory constituent to the moulding sand. However, its addition improves the quality of the moulding sand and hence the casting obtained.

Note: Additives do not impart any binding qualities.

A few commonly used additives used and their properties are mentioned below:

(a) Sea Coal

- It is a finely powdered bituminous coal.
- Its addition ranges from 2-8% by weight of sand.
- Enhances peeling property of castings.
- Improves surface finish of castings
- Prevents sand burn out.

(b) Silica Flour

- It is pulverized silica added in ranges of 5-10% based on sand weight.
- Resists metal penetration in the mould walls.
- Improves surface finish.

(c) Wood Flour (Cellulose material)

- It is a pulverized soft wood (fibrous material)
- Added in ranges of 1-2% by weight of sand.
- Controls sand expansion created by temper water.
- Absorbs excess water and improves flowability of sand during moulding process.
- Improves collapsibility of moulds/cores.

(d) Iron Oxide

- Develops hot strength to moulding sand.
- Aid in the thermal transfer of heat from the mould-metal interface and provides stability to the moulds dimensional properties

SAND MOULDING

Sand Moulding: A mould is a cavity created using metal or refractory sand. The shape of the cavity corresponds to the shape of casting except the dimensions. A mould is referred to as the negative replica of the casting. Mould made of metal is called as metal or metallic moulds and the ones made by using sand is called sand moulds.

Sand moulds or non metallic moulds:

- Sand moulds are made using a mixture of refractory sand along with a binder, additive and water.
- This mixture is referred to as moulding sand.
- A mould cavity is prepared using this moulding sand.
- They are also referred to as non-metallic moulds or refractory moulds.

Moulding sands may be:

- **Natural sand:**
 - Occur readily in nature and contains all the ingredients in the right proportion.
 - The sand can be directly used to prepare the mould.
- **Synthetic sand:**
Are prepared by making different ingredients (sand, binder, water, etc.) in the correct proportion and then used for preparing the moulds.

Properties of moulding sand: An important property of a moulding sand is that, it should produce a sound casting, i.e. a good casting.

To achieve this, the moulding sand should possess the following desired properties:

1. **Flowability:**

- It is the ability of the sand to flow easily and cover all the contours on the pattern, thus take the desired shape.
- The sand with good flowability gets compacted to a uniform density.
- Energy during ramming gets easily transmitted through the sand if the flowability is good.
- Clay and water additions influence flowability.

Good moulding sand should have good flowability property.

2. **Green Strength:**

- It is the strength of the sand when in moist condition or green condition (after compaction).
- A mould with adequate green strength will retain its shape, does not distort and will not collapse while handling it.
- A mould with adequate green strength resists metallostatic pressure and sand erosion while molten metal is flowing in the mould.

Good moulding sand should have good green strength property.

3. Dry strength:

- It is the strength of the sand when there is no moisture in the sand i.e. in the dry condition.
- Hence, a good moulding should be able to develop good dry strength.
- By heating the mould to approximately 200°C, all the moisture in the sand can be removed, the strength of such dried sand represents dry strength.
- Dry sand enhances strength of the mould.
- Resistance to erosion is improved considerably.
- Shape of the mould is retained easily in the dry condition.

4. Hot Strength:

- It is the strength of the sand mould at high temperature above 100°C i.e. if the hot strength of sand is good at 200°C, it means that the sand has the necessary strength when sand is heated and held at 200°C.
- When molten metal is poured into the cavity, the mould gets heated up.
- If the sand does not have sufficient strength at this temperature it will induce casting defects.

Hence, sand should have adequate strength at elevated temperature.

5. Permeability:

- It is the ability of the sand/mould to allow easy escape of gases/vapour through it.
- When molten metal comes in contact with the mould and core surface, moisture, binders and additives present in them produce gases and vapour.
- These tend to go through vents and also pass through the mould surface.
- The sand surface should allow the gases/vapour to escape.
- If these are entrapped in the casting, defects will appear in the casting as pores.

Hence, good moulding sand should have good permeability.

6. Collapsibility:

- It is the ability of the moulding sand to collapse after the casting solidifies. It should break down into pieces at the knock out and cleaning stages, easily.
- Easier the mould breaks, higher is the collapsibility property of the sand.
- If the mould or core sand does not collapse easily, it may obstruct/restrict the contraction of the solidifying casting and result in cracks/tear in the casting.

Hence, the collapsibility of the sand should be good.

7. Bench line:

- It is the ability of the moulding sand to retain its properties during its storage.
- The sand should possess fairly good bench life.

A good moulding sand should have good bench life.

8. Coefficient of expansion:

- Moulding sand should have very low expansion characteristics otherwise sand expansion will occur.
- Lower the value of expansion, lesser is the problem of expansion defects in the mold. Lesser is the cracking tendency of the mold.

9. Adhesiveness:

- It is the property of the moulding sand owing to which the surfaces of the mould are held together.
 - It is because of this property that the sand sticks to the walls of the boxes.
- A good moulding sand should have good adhesiveness.

10. Durability:

- It is the ability of the sand to withstand repeated cycles of heating and cooling and still retain its properties.
- The sand should be reusable i.e. should be able to reclaim the sand.

Requirements of base sand: For producing good casting the sand has to fulfill the following:-

Base Sand:

- *Should be sub angular (grain size)*
- *Should be good grain distribution*
- *Should have high refractoriness*
- *Should have low impurities*
- *Should have low expansion characteristics*
- *Should be thermally stable.*

BASE SAND:

It is a mass of refractory grains. Grains are formed due to the withering action of rocks. It is available in plenty in nature along se beaches, deserts, etc. Bas sand refers to sand grains without any other ingredients. They are normally oxides of elements.

Types of base sand:

- 1) Silica Sand
- 2) Olivine Sand
- 3) Chromite Sand
- 4) Zircon Sand

1. **Silica Sand:** Silica sand is essentially silicon dioxide (SiO_2) found in nature on the bottom and banks of the rivers, lake and seashore. Silica deposits tend to have varying degree of organic and mineral contaminants like limestone, magnesia, soda and potash that must be removed prior to its use, otherwise which affects castings in numerous ways.

Silica sand is available in plenty, less expensive and possess favorable properties. But its high thermal expansion leads to certain casting defects; the reason for which not being used in steel foundries. However, silica sand when mixed with certain additives like wood flour, cereals, (corn flour) saw dust, etc., defects can be eliminated. These additives burn by the heat of the molten metal thereby creating voids that can be accommodated the sand expansion.

2. **Olivine sand:** Olivine sand is typically used in non-ferrous foundries. With its thermal expansion about half of that of silica sand makes it suitable for production of steel castings also. But the high cost restricts its wide use.
3. **Chromite sand:** This is African sand with cost being much higher compared to other sands. Due to its superior thermal characteristics, it is generally used in steel foundries for both mould and core making.
4. **Zircon sand:** Zircon or zirconium silicate possesses most stable thermal properties of all the above discussed sand. The choice for this type of sand arises when very high temperatures are encountered and refractoriness becomes a consideration. But the major disadvantage is that, zircon has trace elements of uranium & thorium which is hazardous in nature, thereby restricting its use in foundries.

TYPES OF SAND MOULDS: Moulds prepared with sand are called “*sand moulds*” or “*temporary moulds*”, (when moulds are with metal, it is called metallic moulds or permanent moulds) as they are broken for removing the casting. The different types of sand moulds are:-

- Green sand mould
- Dry sand mould
- No bake sand mould

Green Sand mould: The moulding sand is in the moist state at the time of metal pouring. The main ingredients of green sand are silica sand, clay and moisture (water). Additives may be added in small quantity to obtain the desired properties of mould/casting. Nearly 60% of the total castings are prepared from green sand moulds.

Advantages:

- Prepared for simple, small and medium castings
- Suitable for mass production
- Least expensive
- Sand can be reused many times after reconditioning with clay & moisture.

Disadvantages:

- Moulds/cores prepared by this process lack in permeability, strength and stability.
- They give rise to many defects like porosity, blow holes, etc.
- Moulds/cores cannot be stored for long time.
- Not suitable for large castings.
- Difficult to cast thin and intricate shapes.

Dry sand mould: The dry sand mould is prepared in the normal manner as that of green sand mould, i.e., by mixing base sand, clay, water and other additives. Strength is realized after baking the mould in the oven, to remove moisture present in them. Baking is carried out for 6-12 hours at 200-300°C, depending on the size of the mould and type of metal being poured.

Advantages:

- Moulds are stronger than green sand moulds.
- Surface finish of the casting is better.
- Defects related to moisture are eliminated.

Disadvantages:

- Production is slower, labour and cost due to baking process.
- Under baked or over baked moulds is another disadvantage.
- Not suitable for large & heavy castings as they are difficult to bake.

No Bake sand moulds: A no bake or self setting sand mould is one that does not require baking. The main ingredients are base sand, binder (resin type), hardener and a catalyst or accelerator. The bonding strength developed in moulds by means of a self-setting chemical reaction between binder and hardener. In some cases, a catalyst or an accelerator is added to speed up the chemical reaction.

Advantages:

- Higher strength about 50 to 100 times that of green sand moulds.
- Patterns can be stripped within a few minutes after ramming, which is not possible in green and dry sand mould.
- Moulds can be stored for longer periods.
- Highly simplified moulding.
- Better dimensional accuracy & stability.
- Improve casting quality.
- Surface finish is excellent.

Disadvantages:

- Use of resin and catalyst causes lot of environmental problem both within (i.e. during mixing & pouring) and outside (dumping of sand).
- Resins and catalysts are expensive.
- Unsafe for human operators.
- Due to high strength & hardness, reuse of sand is slightly difficult.

MOULDING SAND MIXTURE INGREDIENTS FOR DIFFERENT SAND MIXTURES

A moulding sand is a mixture of base sand, binder and additives. Ingredients for dry sand mixture are similar to that of green sand.

a. Ingredients for Green Sand Mixture

Green sand mixture is composed of base sand, binder, moisture and additives.

Base Sand: Silica sand is used as the base sand. It possesses favourable properties, inexpensive and can be reused many number of times. The amount of silica sand added may vary depending on the requirements.

Binder: Bentonite (clay binder) is the widely used binder for bonding sand particles. It is activated in the presence of water. A best bond between the sand can be obtained with bentonite varying from 6-12% and water 3-5%.

Additives: Additives are added in small quantities to develop certain new properties or to enhance the existing properties of moulding sand. Sea coal, silica flour, wood flour and iron oxide are commonly used additives.

b. Ingredients for No-bake sand mixture:

Of all the various no-bake sand mixture, viz., Furan system, Phenolic urethane system, Alkyd system, sodium silicate binder system, etc. Ingredients of Alkyd binder system which is one of the most widely used binder system is discussed below.

Base sand: Silica sand is used as the base sand.

Binder: The alkyd binder system consists of three parts:

Part – A (binder)

Part – B (hardener)

Part – C (catalyst)

Part – A (binder): The binder is alkyd resin which is obtained by reacting linseed oil with a polybase acid like iso-phthalic and solvents like turpentine, kerosene or mineral spirit to improve flowability. Its addition ranges from 2-5% based on weight of sand.

Part – B (hardener): The hardener is a reacted product between cobalt/lead salts and naphthanic acid. Its addition ranges from 5-10% based on weight of binder.

Part – C (catalyst): Methylene-diphenyl-Di-isocyanate commonly known as MDI is used as catalyst to speed up the chemical reaction. Its addition ranges from 20-25% based on weight of binder.

METHODS USED FOR SAND MOULDING

The various sand moulding methods are:-

- Bench moulding
- Floor moulding
- Pit moulding &
- Machine moulding

Bench Moulding: Bench moulding is preferred for small jobs and is carried out on a bench of convenient height. The bench moulder (mould maker) prepares the mould manually while standing.

Floor Moulding: Floor moulding is preferred for large size moulds that cannot be carried out on benches. In most of the foundries, moulding is carried out on floors irrespective of the size of jobs.

Pit moulding: Large castings that cannot be accommodated in mould box (flasks) are made in pits dug on the floor. The pits form the drag part of mould and a separate cope box is placed above the pit. The mould maker enters the pit and prepares the mould. The cope box is rammed using dry sand with risers placed at suitable location.

The walls of the pit are lined with brick and the bottom is covered with moulding sand with connecting vent pipes to the floor level for easy escape of hot gases. A crane is used for handling the cope box and other operations.

Machine moulding: In bench, floor and pit moulding, all the operations viz., ramming, withdrawing pattern, rolling flasks, etc., are done manually by mould makers. But when large number of castings are to be produced manual operations consumes more time and also accuracy and uniformity of moulding varies. To overcome this difficulty, machine moulding is used. The operations performed by machines includes:

- Ramming moulding sand: By jolt operations or Jolt squeeze machines.
- Rapping the pattern: Patterns are rapped in the sand with vibrators that are operated electrically or by compressed air.
- Removal of pattern: By raising or lowering the mould, or by raising or lowering the pattern.

CORES

Cores are used in the mould to produce mainly hollow castings. It is the only method through which cavities can be produced in the casting without machining.

Core sand is used to prepare the core. A core consists of base sand, a binder and water if required. Special types of binders are used for the purpose. Core sand is filled in a metal or wooden die then rammed to get the desired geometry of the die. The shaped sand represents green core. This core gains strength after suitable treatments, depending on the type of binder used.

TYPES OF CORES

Cores are classified based on:

- | | | |
|--|----------------------------|---|
| a) Condition of core: | i. Green sand core | - contains moisture |
| | ii. Dry sand core | - Cores does not contain moisture, core in the dried form |
| b) Binder used | i. Resin bonded core | - contains resin as binder |
| | ii. Sodium silicate core | - contains sodium silicate as the binder |
| | iii. Oil bonded core | - contains oil as binder |
| | iv. Shell core | - contains urea/phenol formaldehyde resin as binder |
| c) Hardening process used | i. CO ₂ process | - uses CO ₂ gas to harden the sand |
| | ii. No bake oil | - uses air to harden the sand |
| | iii. Furan no bake | - uses heating to harden the sand |
| | iv. Nishiyama | - uses chemical reaction to harden the sand |
| | v. Fluid sand | - uses chemical reaction to harden the sand |
| d) Shape & position of the core | i. Horizontal core | - core placed in horizontal |
| | ii. Vertical core | - core placed in vertical position |
| | iii. Balanced core | - core hanging on one side |
| | iv. Hanging core | - core suspended from the top. |

Green sand core: A green sand core is composed of a mixture of silica sand, binder (bentonite), moisture and additives. The preparation of green sand core is similar to that used for green sand mould.

Dry sand core: The sand used for preparing a dry sand core is different from that used for dry sand moulds. A dry sand core is composed of a mixture of silica sand and binder. The binder may be sodium silicate, Portland cement, linseed oil, mineral oil, natural resins, etc.

Binder used : explained above.

Hardening process used : explained above

Shape and position of the core:

- a. **Horizontal core:** The core is placed horizontally in the mould, it is known as horizontal core. The core prints are provided at both ends of the core to rest in the seats initially provided by the pattern. These core prints helps the core to be securely and correctly positioned in the mould cavity.

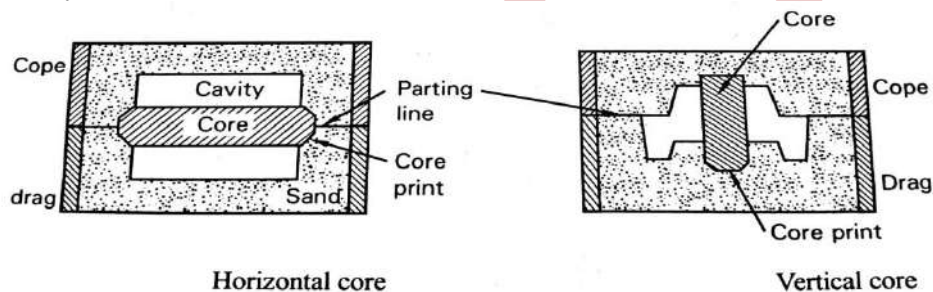

- b. **Vertical core:** When the axis of the core is vertical, it is known as vertical core.

- c. **Balanced core:** A balanced core is one that is supported from its one end only. Such cores are used when the cavity required is only to a certain depth.

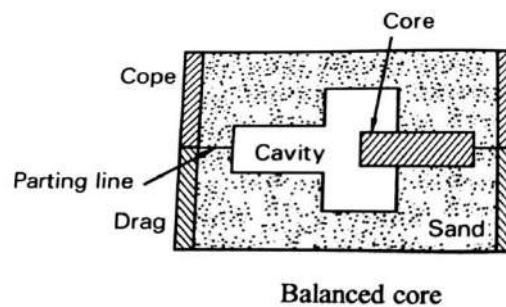

- d. **Hanging core:** The core is supported from the top, the core hangs vertically from the mould and the core may be provided with a hole for molten metal to flow.

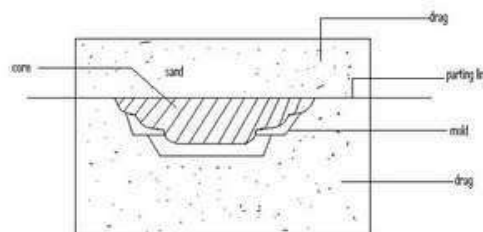

- e. **Drop core:** Drop core is used when the axis of the desired hole does not coincide with the parting line of the mould, i.e., the core is required to be placed either above or below the parting line.

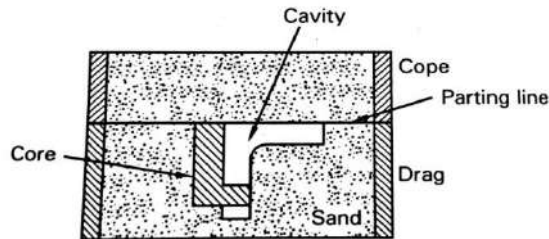

Drop core

- f. **Kiss core:** In some cases, pattern cannot be provided with core prints and hence no seat will be available as a rest for the core. In such cases, the core is held in position between the cope and the drag by the pressure exerted from the cope on the drag. Such a core is called a kiss core and is shown in fig.

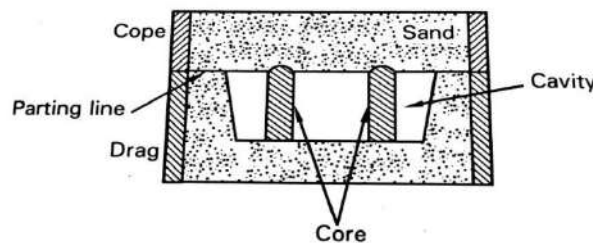

Kiss core

- g. **Ram-up core:** When a core is to be placed in an inaccessible position, it is difficult to place it after ramming the mould. The core used in this case is called a ram-up core and is placed in the mould along with the pattern before ramming fig.

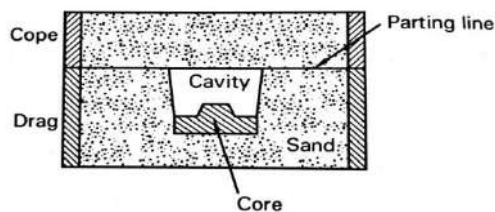

Ram-up core

METHOD OF MAKING CORES

Core making consists of the following four steps:

1. Core sand preparation
 2. Core making
 3. Core baking
 4. Core finishing
1. **Core sand preparation:** The core sand of desired type (dry sand) and composition along with additives is mixed manually or using muller of suitable type.
 2. **Core making:** Cores are prepared manually or using machines depending on the needs. Machine like jolt machine, sand slinger, core blower, etc., are used to for large scale continuous production, while small sized cores for limited production are manually made.

A core box is similar to a pattern that gives a suitable shape to the core fig. shows a core box used to produce rectangular shaped cores. The procedure involved for preparing core is as follows:

- The prepared core sand mixture is rammed manually into the core box.
- The core box is inverted over a core plate and rapped in all direction using wooden mallet.
- The box is lifted vertically to leave the core on the core plate.
- The core along with the core plate is sent for baking.

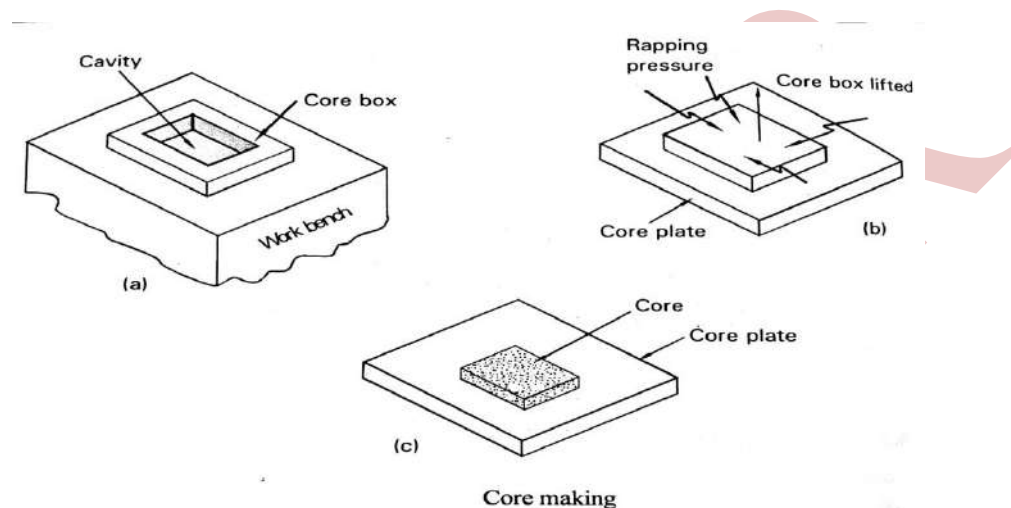

3. **Core baking:** Cores are baked in ovens in order to drive away the moisture in them and also to harden the binder thereby imparting strength to the core. The temperature and duration for baking may vary from 93-232°C and from a few minutes to hours respectively depending on the size of the core and type of binder used.
4. **Core finishing:** The baked cores are finished by rubbing or filing with special tools to remove any fins, bumps, loose sand or other sand projection from its surface. The cores are also checked for dimensions and cleanliness. Finally, if cores are made in parts, they are assembled by using suitable pastes, pressed and dried in air before placing them in mould and cavity.

BINDERS USED FOR CORES

Binders used for core making are of various types: each type used to provide some desired property to a core for particular use or set of conditions. The core binders commonly used are discussed below:

a) Binders that become firm at room temperature.

The binders that come under this group include:

- **Sodium silicate**

Sodium silicate is mixed with silica sand to prepare a core of desired shape and size. Vent holes are made in the core after which carbon-dioxide gas is passed through it. The core hardens rapidly within a few seconds after gassing is stopped.

- **Port Land Cement**

Port land cement is mixed with silica sand and water to prepare a core of desired shape

after which it is made to set (dry) in a room for about 72 hours. The strength develop with this binder is very high and hence, preferred for heavy steel and gray iron castings.

- **Rubber Cement (Rubber latex)**

Bonding of cores with this binder is a patented process. Silica sand is mixed with water, and then the rubber latex (obtained from plant) is added. The core is rammed and allowed to harden at room temperature.

- **Synthetic resins (No bake binders)**

Synthetic resins like phenol and urea formaldehyde are used as binders. They are mixed with hardeners and/or catalyst to bring about a chemical reaction. Strength development in cores takes place within a few minutes after mixing.

b) Binder that become firm on baking

This group of binders does not develop their strength by chemical or physical changes, rather they become hard on heating (baking). Binders materials of this group include:

- Vegetable oils ex. Linseed oil
- Marine animal oil ex. Whale oil
- Cereal binder
- Dextrin made from starch
- Molasses (by product of sugar industry)
- Pitch (a coal tar product)
- Protein binders ex. Gelatin & glues.

c) Binder that harden on cooling after being heated

A binder that softens on heating and hardens on cooling includes natural resins like:

- Gum resins – obtained by tapping the living tree and distilling the gum.
- Wood resins – obtained from pine stump wood.
- Limed wood resins – these are wood resins treated with lime
- Coal tar resins – a product of coal tar industry.

d) Other binders

- Clay binders – bentonite mixed with water.
- Saw dust and wood floor – although not pure binders (they provide little adhesive strength), they serve to improve the collapsibility of the core.

GATING

The concept of gating is very important, as it helps one to learn the controlled flow of molten metal from the crucible or ladle into the mould cavity.

The term gating or gating system refers to all the channels or cavities through which the molten metal flows to reach and fill the mould cavity. Fig shows a simple gating system which consists of the following components.

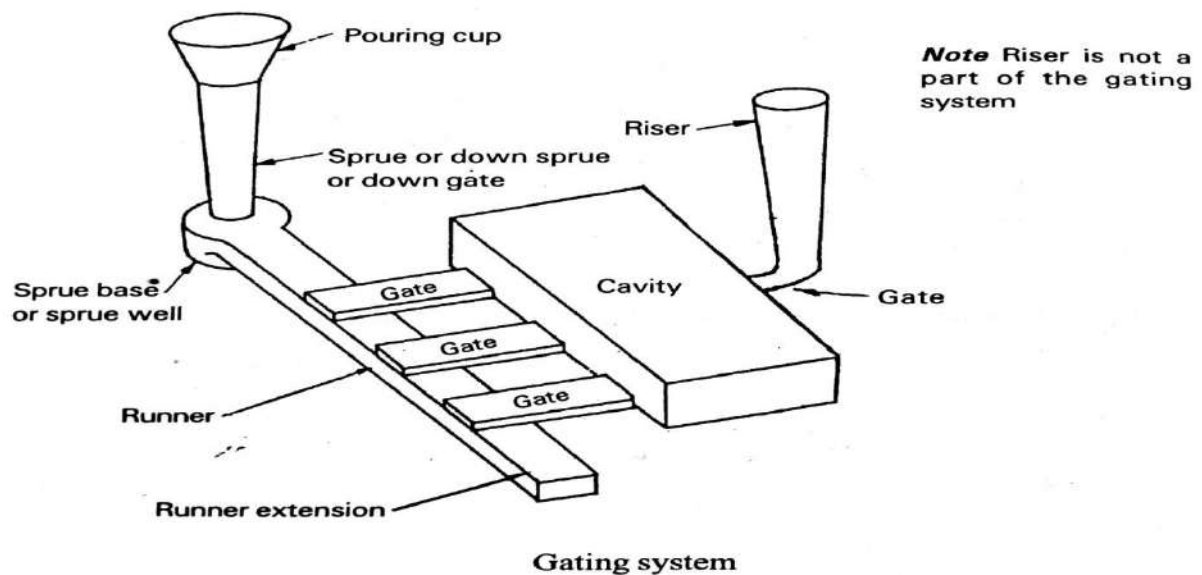

- a. Sprue
b. Pouring cup
c. Runner
d. Ingates or Gate

a) Sprue

A sprue is a vertical passage way through which the molten metal will enter the runner. It is also called „down gate“ or „down sprue“. The sprue is tapered in cross-section with its bigger end at the top connected to the pouring cup while its smaller end connected to the runner.

b) Pouring cup

The enlarged portion (usually funnel shaped) of the sprue at its top into which the molten metal is poured is called pouring cup. (Fig. 15 a & b). In some cases, pouring basin is used instead of cup. The pouring basin has a larger opening as shown in fig 15(a). It makes pouring easier, eliminates aspiration (air pick-up) and reduces the momentum of the liquid flowing into the mould settling first into it.

c) Runner

The runner is a horizontal passage way through which the molten metal flows into the gates. The cross section of the runner runner may be square or trapezoid and its length is very large compared to its width.

d) Runner extension

It is a small portion of the runner that extends beyond the last gate. It is used to trap the slag in the initial molten metal.

e) Ingates

The ingates or gate is a short passageway which carries the molten metal from the runner to the mould cavity. The gates used may vary in number and depends on the size of the casting and rate of solidification of molten metal. A gate may be built as a part of the pattern or it may be cut in the mould using gate cutter tool. The combination of sprue base, runner and ingates completes the total pouring system of any casting.

RISERING

When the molten metal solidifies, it shrinks in volume. At this stage, if it does not have a source of more molten metal to feed as it shrinks, voids appear leading to defects in castings. This problem is overcome with the use of risers.

A riser or feed head is a vertical passage that stores the liquid metal and supplies (feed) the same to the casting as it solidifies. This means that the metal in the riser must stay liquid longer than the metal in the part being cast.

Requirement of a riser

- a) A riser must be large enough that the casting detail it is intended to feed. This helps continuous feeding of liquid metal to the solidifying casting so that shrinkage cavities are eliminated.
- b) The riser must be kept open to the atmosphere and placed in such a location that it maintains a positive pressure of liquid metal on all portions of the casting it is intended to feed.
- c) A riser should be located in a position that will cause directional solidification from the casting towards it.

PRINCIPLE OF GATING SYSTEM

1. A good gating system should help easy and complete filling of the mould cavity.
2. It should fill the mould cavity with molten metal with least amount of turbulence.
3. It should prevent mould erosion and gas pickup.
4. It should establish proper temperature gradient in the casting.
5. It should promote directional solidification.
6. It should regulate the rate of flow of metal into the mould cavity.

TYPES OF GATES

The common types of gate are:

1. Top Gate
2. Bottom Gate
3. Parting line Gate
4. Step Gate

1. Top Gate

The top are used for simple casting. Molten metal flows into the mould cavity directly from the top. They are the most efficient type of gating. Simple to mould.

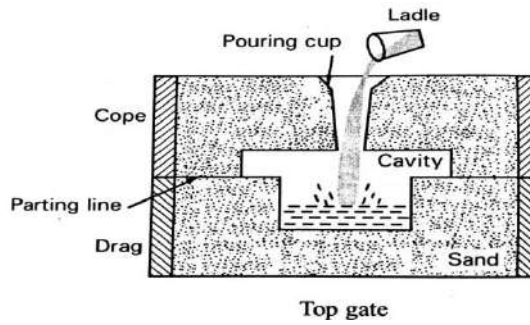

2. Bottom Gate

The bottom gates are used for denser metals such as steel. Molten metal flows into the mould cavity from the bottom and slowly rises up. It avoids erosion of mold taken more time in moulding. Bottom gate is shown in fig.

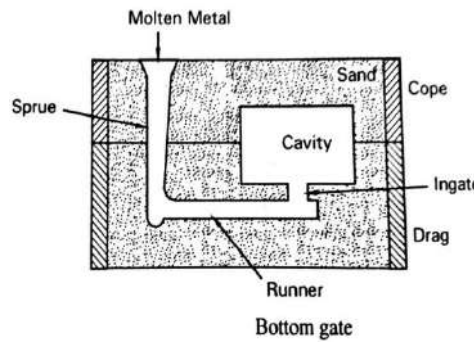

3. Parting line gate

The gates located at the junction of cope and the drag boxes. They can be easily prepared. Molten metal flows into the cavity from a certain height. These are used for most of the non-ferrous alloys and steel castings Fig.

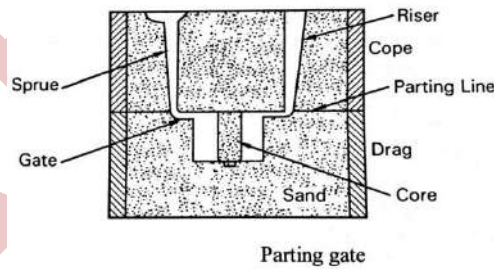

4. Horn Gate

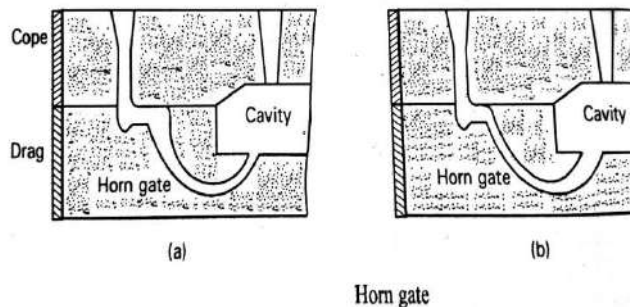

TYPES OF RISERS

Basically riser can be classified as open riser and blind riser. The open riser is kept open to the atmosphere at the top whereas the blind riser is close to the atmosphere.

Open Riser

An open riser is a riser provided in the mould cavity when the top portion is open to the atmosphere. It is easy to mould. Further, an open riser can be classified as Top riser – when the riser is placed above the casting. Side riser - when the riser is placed by the side of the casting. Top risers are extensively used since its efficiency is very high. In open riser molten metal is subjected to atmospheric pressure directly.

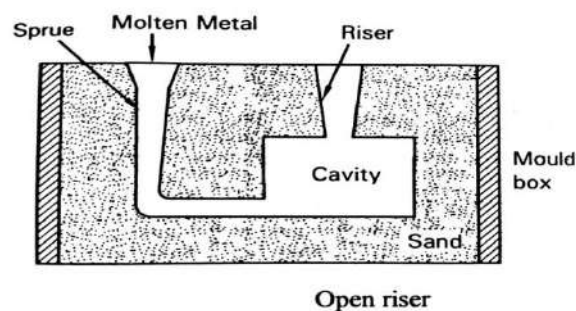

Blind riser

A blind riser as shown in fig. is one which is completely enclosed in the mould and not exposed to the atmosphere. Due to this, the metal in the riser cools slower and thus stay liquid longer promoting directional solidification.

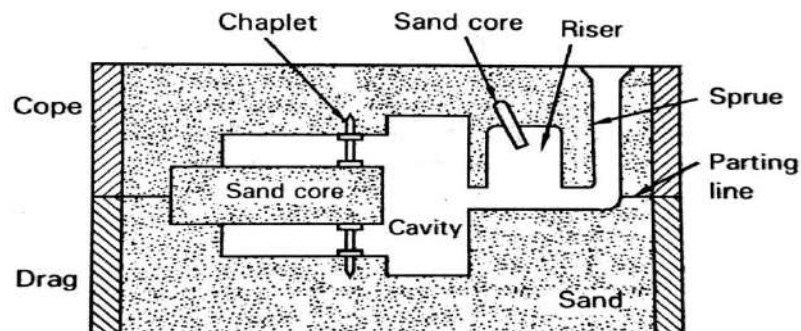

Note Chaplets serve only to support the core. When the chaplet comes in contact with the molten metal, it melts and becomes part of the casting

FETTLING AND CLEANING OF CASTINGS

Castings are to be separated from sand mould box before the gates and risers are removed. This is referred to as fettling and cleaning of casting. The steps involved are:

Fettling

Shake out → sand,
 Sand lumps are broken
 Cleared of nails, wires, etc
 ↓
 Returned to sand Muller
 For reuse for moulding

Casting and mould boxes are separated



Returned to the moulding section
 to be used again

→ Cleaning operation of castings

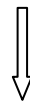

Involves

- Removing sand by shot blasting
- Removing core sand
- Removing moulding sand on the casting surface
- Removing gates and risers
- Removing fins, excess metal, sand, etc.,
- Leveling the surface by grinding
- Rectifying the casting from defects

- ❖ Cleaning operation depends on the casting shape, size, metal and the process used.
- ❖ Sand cores are removed by shaking, chipping, poking or dissolving, etc.,
- ❖ Gates, risers, fins are removed by oxy-acetylene flame cutting, hammering, abrasive grinding wheel, etc.,
- ❖ Sand sticking on the casting surface removed by shot blasting or sand blasting.

MOULDING MACHINES

Moulding machines are used to maintain mold quality, reduce allowances, have reproducibility in molding, casting and to enhance productivity.

The following are moulding machines, classified based on the method of ramming.

- a. Jolt machine
- b. Squeeze machine
- c. Jolt-squeeze machine
- d. Sand slinger

a. Jolt Machine

The machine consists of a cylinder with two passages on for permitting compressed air at the bottom and another for air to go out. A piston is located in the cylinder and can move up and down. The piston carries a table at the top. On the top of the table a pattern can be fixed and mould box can be placed around it. A control panel is located near the machine to operate it. The machine is located on a firm and rigid concrete base. A hopper carrying sand mixture is located above the machine. By operating the lever compressed air can be made to flow through the bottom of the piston.

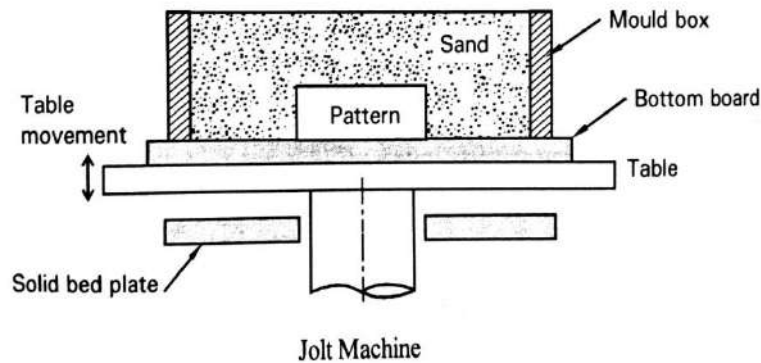
**Working operation:**

- First the moulding sand is filled into the box to cover the pattern.
- The pattern is placed on the table. Moulding box is placed on to the table. Compressed air let into the cylinder.
- Now the table starts moving upwards till the bottom of the piston reaches the top portion.
- At top portion the air escapes out causing a drop in the pressure inside the cylinder.
- Due to its own weight the table along with the box drops down.
- Again the compressed air lifts the piston up till top point and the box is dropped downwards.
- A jolting action is created.
- The process is repeated several times to achieve a desired hardness in the mould.
- Sand is compacted more at the bottom due to jolting action.
- Cope and drag boxes are prepared this way.

b. Squeeze Machine

It consists of a cylinder and piston assembly as in jolting machine. It has only one opening in the cylinder connected by a two way valve. Through this valve compressed air can be let inside the cylinder or let out. Thus the piston can be lifted or lowered inside the cylinder. The piston head carries a table on which the platen/board corresponding to the inside cross section of the mould box is fixed. This board when positioned above the box will squeeze the sand in it when the piston moves upwards. The platen can be swung to one side for placing the mold box and filling the sand.

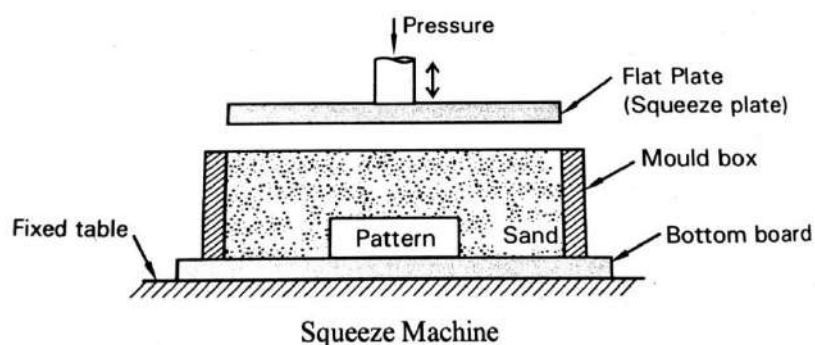
**Working operation:**

- First the mould box is kept on the table fixed with the pattern.
- Moulding sand is filled in the box at least 25% in excess of the box volume.
- The platen/board is brought in position above the box.
- Compressed air is then allowed inside the cylinder through the valve.
- Now the piston will move upwards along with the box.
- The platen will squeeze the sand in the box during this period.
- Compacted sand will have more compaction on the top and less at the bottom due to squeezing action.
- The air pressure is released now. The piston and box move down wards.
- The box is ejected out using ejector pins.
- One half of the mould is ready now.
- Similarly next half is done and assembled.
- Two machines placed side by side are used to prepare cope and drag molds.
- Suitable for small works and shallow boxes.

c. Jolt and Squeeze Machine

Here both jolt and squeeze action are imparted to the sand. Constructional features

- It consists of a piston (**P**) carrying a table (**T**)
- Piston is housed in a sleeve (**S**)
- Sleeve has an opening O_1 at the top and another opening (O_3) at the bottom
- Sleeve is housed in an outer casing (**C**) which has a firm base (**B**)
- The casing has 3 openings O_2 , O_4 and O_5
- Opening O_4 is connected to the valve 1 referred to as Jolt valve
- Opening O_5 is connected to valve 2 referred to as squeeze valve
- Opening O_2 is the exhaust part and connects the opening O_1 Valves 1 and 2 are connected to a pipe which in turn is connected to compressed air supply.

The pattern for moulding can be mounted on the table and the moulding box can be placed in position by using locating pins.

A squeeze head at the top of the machine is used to squeeze the sand in the mould box.

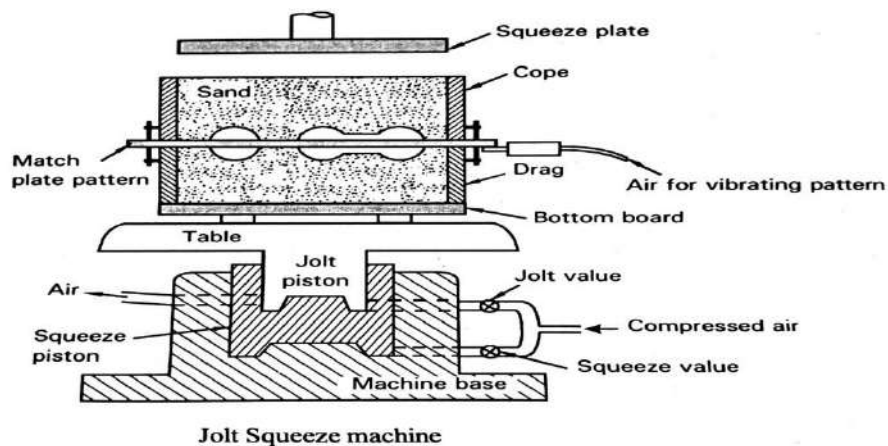

Working Operations:

To start with the piston and sleeve are in the bottom position. O_1 , O_2 and O_3 , O_4 are connected and are in line. By opening the valve 1, compressed air is made to pass through the opening O_4 , O_3 . Now the piston carrying the mould box with sand mixture moves upwards till the bottom of the piston just move above the opening O_1 . Suddenly the compressed air below the piston escapes out through O_1 , O_2 , opening. This results in drop in the pressure inside the sleeve below the piston. Due to this the piston drops downwards causing jolting action. The sand gets compacted. Now the connection between O_1 , and the sleeve chamber is cut off. Since the valve 1 connects O_4 , and O_3 , this will again increase the pressure inside the sleeve. This once again lifts the piston upwards. When the bottom of the piston crosses the opening O_1 , the pressure drops once again causing jolting. This can be repeated several times. Now for bringing about squeezing action, valve 1 is closed and valve 2 is opened. This results in establishing connection between valve 2 and opening O_5 . This causes increase in the pressure at the bottom of the sleeve. Now the piston and the sleeve now get lifted upwards. The squeeze head is brought in line with the mould box containing sand. This results in the squeezing action of the sand against the squeeze head. Squeezing action can be repeated. By this mechanism both jolting squeezing can be imparted to the sand in the mould. The hardness of the mould will be uniform throughout from top to bottom.

d. Sand Slingers:

- Sand slinger is used for large boxes for preparing large molds.
- Large amounts of sand is handled.
- Uniform ramming is obtained.
- Ramming is fast.
- Initial cost is high.
- A number of moulds can be prepared one after the other, around the slinger.

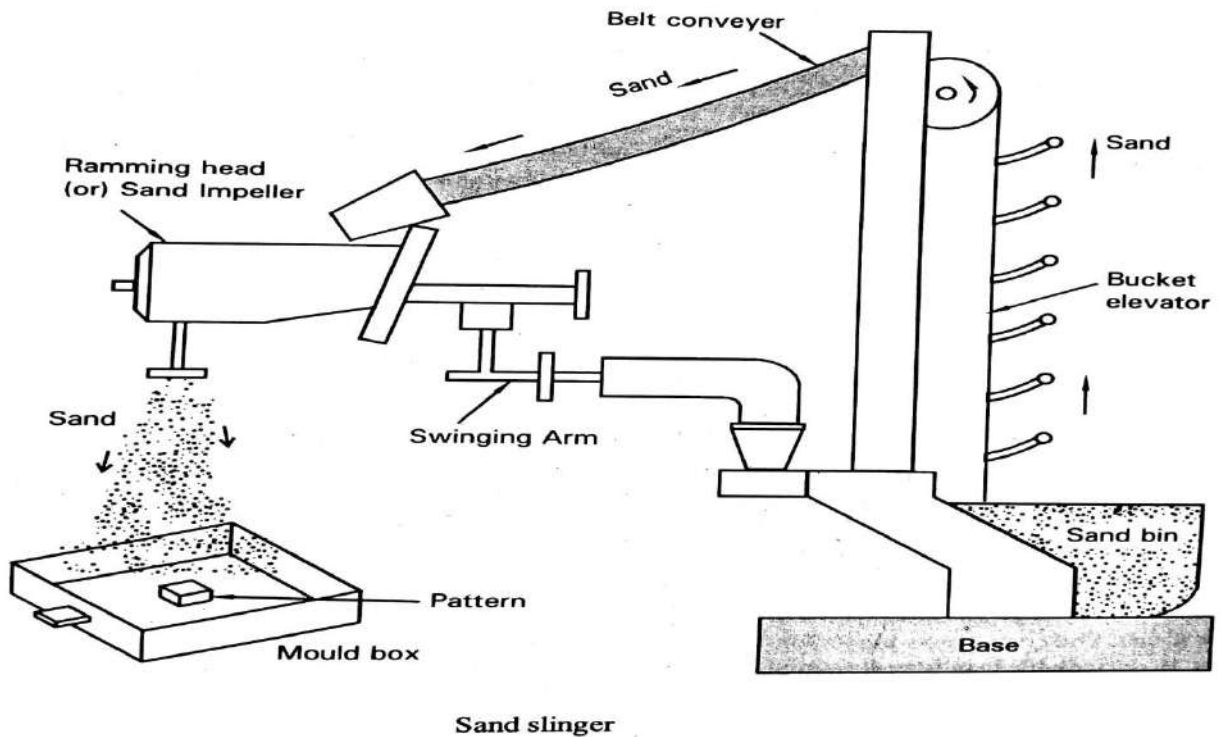

Steps in moulding using sand slinger:

1. Mould boxes with patterns are kept around the base of the slinger.
2. Mixed sand is dumped in the container
3. The slinger is switched on.
4. The conveyor buckets carry sand to the top and delivers to the belt conveyer.
5. The sand is now conveyed into the horizontal hopper containing a screw conveyor.
6. At the end of the hopper an impeller keeps rotating and carries the sand mixed from the screw conveyor and throws it out.
7. The sand at high velocity is thrown above the pattern and gets consolidated.
8. Uniform hardness is obtained in the mould.

MODULE-2**MELTING & METAL MOLD CASTING METHODS****STUDY OF IMPORTANT MOULDING PROCESSES**

Moulds can be prepared with *sand* or *metal*. There are various *sand moulds* and *metallic moulds* in which castings are made. The following moulds are discussed below:

(a) Sand Moulds

- Green sand mould
- Dry sand mould
- Core sand mould
- Carbon dioxide mould (CO₂ mould)
- Shell mould
- Investment mould
- Sweep mould
- Full mould

(b) Metal moulds

- Gravity die casting or Permanent mould casting
- Pressure die casting
- Continuous casting
- Centrifugal casting
- Squeeze casting
- Slush casting
- Thixocasting process

a. SAND MOULDS**Green sand mould:**

Green sand moulding is the most widely used process for casting both ferrous and non-ferrous metals.

Procedure involved in making green sand mould:

- a) It is made from silica sand (85-92%), clay (bentonite binder) - (6-12%), water (3-5%) and additives are mixed to prepare green sand mixture.
- b) The pattern is placed on a flat surface with the drag box enclosing it as shown in fig 1(a). Parting sand (*it is dried silica sand*) is sprinkled on the pattern surface to avoid green sand mixture sticking to the pattern.
- c) The drag box is filled with green sand and rammed manually till its top surface as

shown in fig.. The drag box is now inverted so that the pattern faces the top as shown in Fig. Parting sand is sprinkled over the mould surface of the drag box.

- d) The cope box is placed on top of the drag box and the sprue and riser pin are placed in suitable locations. The green sand mixture is rammed to the level of cope box as shown in fig.
- e) The sprue and the riser are removed from the mould. The cope box is lifted and placed aside, and the pattern in the drag box is withdrawn by rapping it carefully so as to avoid damage to the mould. Gates are cut using hand tools to provide passage for the flow of molten metal. Fig. The mould cavity is cleaned and finished. Cores, if any, are placed in the mould to obtain a hollow cavity in the casting fig.
- f) The cope is now placed on the drag box and both are aligned with the help of pins. Vent holes are made to allow the free escape of gases from the mould during pouring. The mould is made ready for pouring fig.

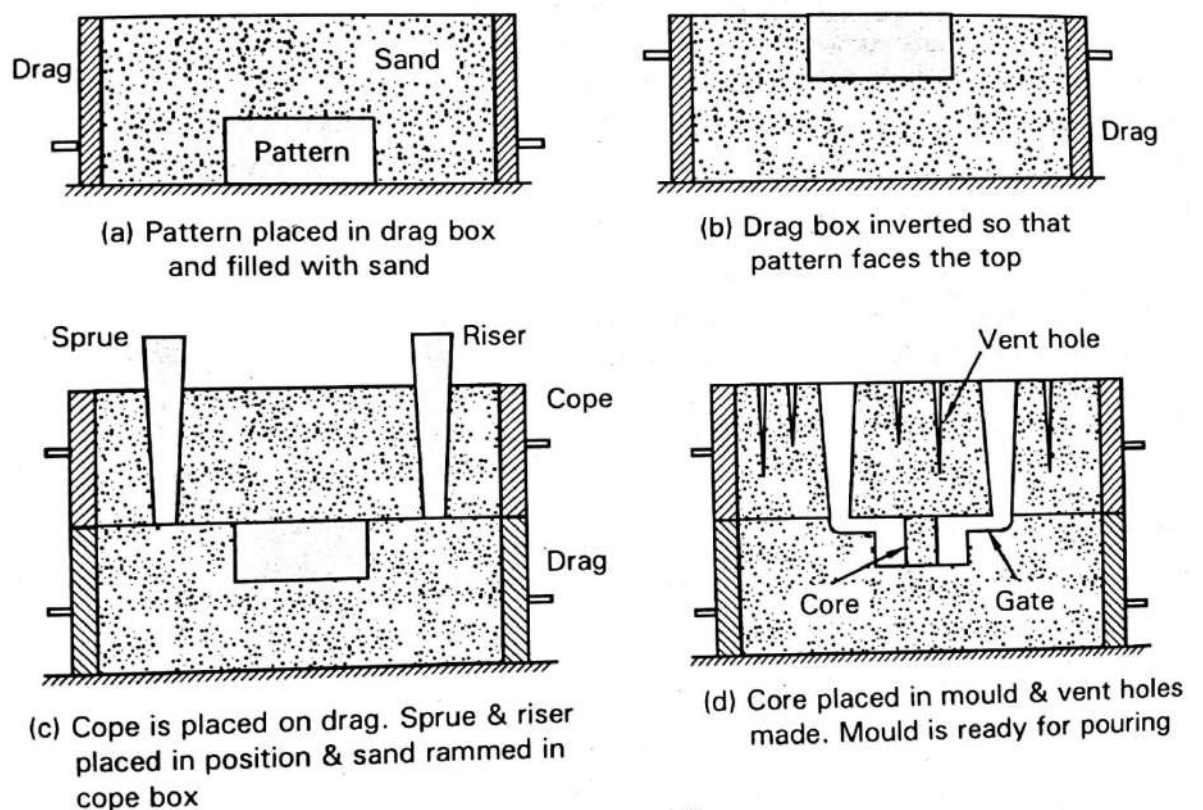

Green sand moulding

Advantages of green sand moulding:

- Least expensive method.
- Sand can be reused many times after reconditioning with clay and moisture.
- Preferred for simple, small and medium size castings.
- Suitable for mass production.

Disadvantages:

- Moulds prepared by this process lack permeability, strength and stability.
- They give rise to many defects like porosity, blow holes, etc., because of low

permeability and lot of steam formation due to moisture presence.

- Moulds cannot be stored for quite long time.
- Not suitable for very large castings.
- Surface finish and dimensional accuracy of castings are not satisfactory.

Dry Sand Moulding

Dry sand moulding is prepared in the same manner as that of green sand moulding, except that the mould is baked in a oven to remove the moisture present in the sand and also to harden the moulds.

Advantages:

- Strength and stability of dry sand moulds is high when compared to green sand moulds.
- Baking removes moisture and hence defects related to moisture are eliminated.
- Dry sand moulds give better surface finish and dimensional tolerance of castings.

Disadvantages:

- Consumes more time, labour and cost due to baking process, hence not suitable for mass production.
- Not suitable for large and heavy size castings, as they are difficult to bake.
- High capital cost of baking moulds in oven.
- Under baked or over baked moulds is another disadvantage.

Core sand moulding

In this process, sometimes complete mould can be obtained by assembling a large number of intricate cores to obtain the desired mould cavity and the cores are baked to develop greater strength. Such a mould is called core sand mould. This is a useful moulding process when the intricacy of the casting is such that green sand moulding becomes impracticable. The motor block is a good example. Good surface finish can be obtained.

Carbon dioxide (CO₂) moulding

Carbon dioxide moulding also known as sodium silicate process is one of the widely used process for preparing moulds and cores. In this process, sodium silicate is used as the binder. But sodium silicate activates or tend to bind the sand particles only in the presence of carbon dioxide gas to form silica gel & sodium carbonate. For this reason, the process is commonly known as CO₂ process, as shown in fig.

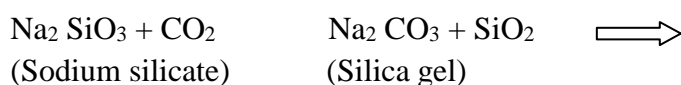

Silica gel acts as a strong binder between silica sand grains and this process takes place without the application of heat.

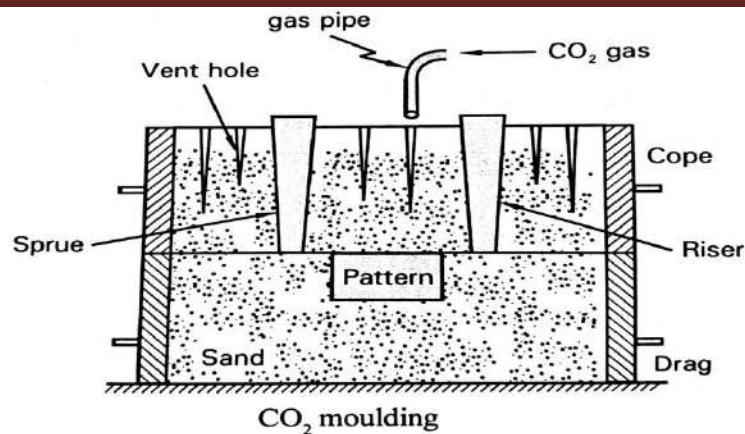
**Advantages:**

- Operation is faster, moulds and cores can be used immediately after processing
- Eliminates baking ovens
- Semi skilled labourers can be used.

Disadvantages:

- Moulds are more expensive compared to other process.
- Difficulty is reclaiming the used sand.

Shell Moulding

- It is a special form of sand moulding.
- It is used for producing small castings (up to 50 Kg steel castings)
- Very intricate, accurate, very good surface finish castings can be produced.
- Machining can be eliminated almost.
- Sand mix consists of washed and dried fine sand (+60 – 150 sieve), 3-4% thermosetting binder (urea/phenol formaldehyde) resin.
- Sand mix is prepared dry in a mixer and taken in a box.
- A metal pattern (aluminium) is heated 200-250°C and coated with the releasing agent. (silicon grease) (only one half of the pattern is used).
- The sand mix is dumped on the heated metal pattern.
- A thin layer/shell of sand is formed on the pattern in about 30 sec.
- Now the shell along with the pattern is cured in a oven at about 300 °C for 2 to 3 min. to make the shell strong.
- The shell is ejected out of the pattern.
- Similarly another half of the shell is prepared.
- Two halves are joined together with the gum.
- The completed shell is kept in an empty mould box and packed with sand, metal shots or gravel as support.
- Molten metal is poured through the sprue and castings are made.
- The pattern along with gates and riser are fixed on to a metal plate to facilitate preparing the shell, i.e., heating, coating with the resin sand and ejecting the shell easily. Fig. 3.

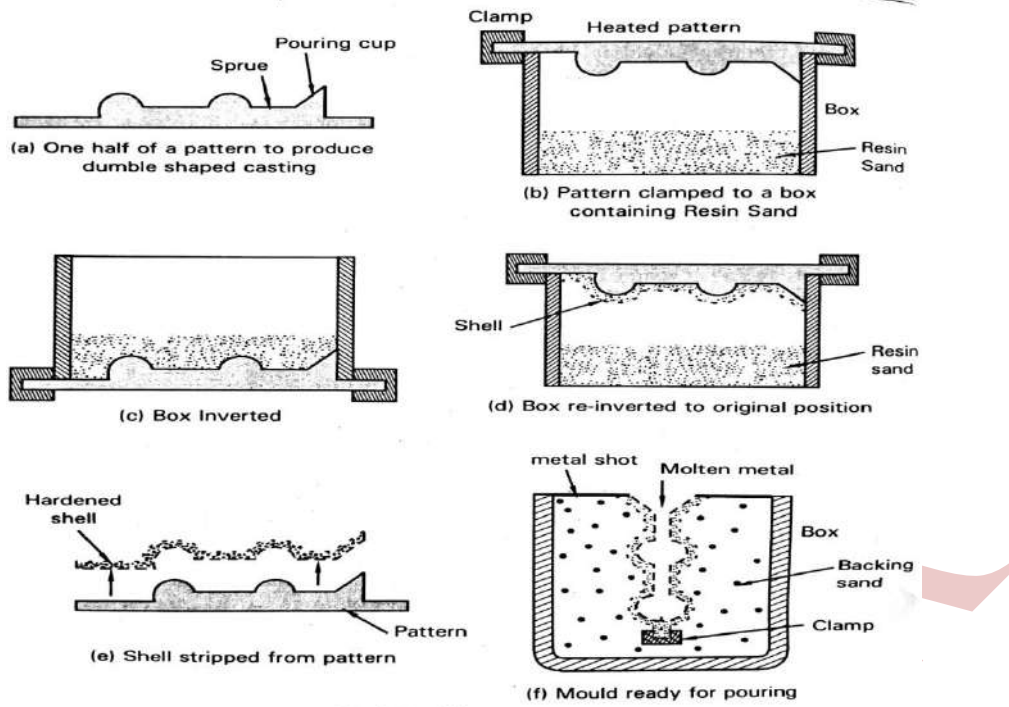

Shell Moulding

Investment shell moulding (Investment moulding)

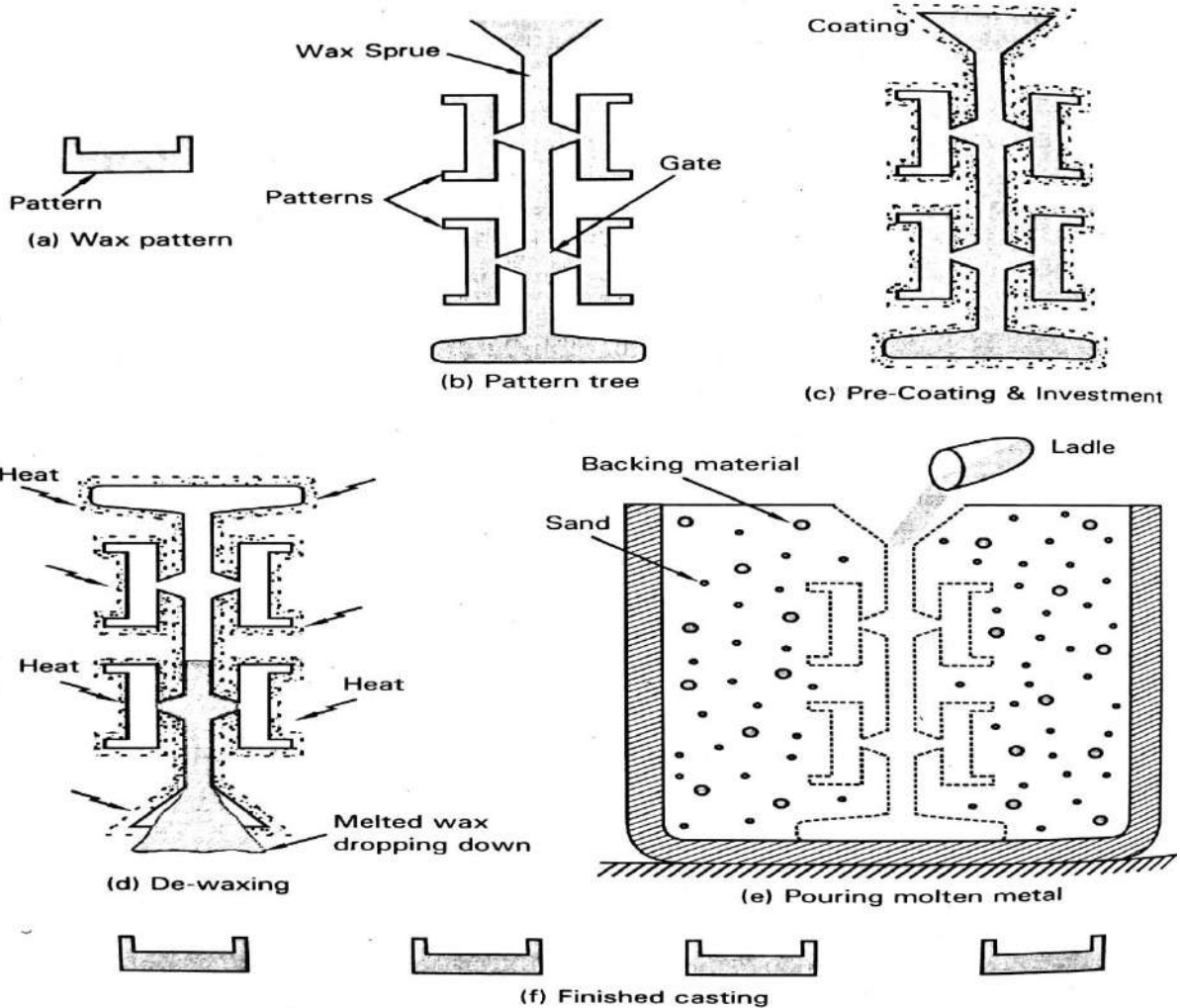

Investment moulding

- Is a process to produce intricate, complex shape and highly smooth surface casting.
- Absolutely no machining is required on the casting.
- Any metal or alloy can be cast in the shell.
- A disposable pattern material such as wax is used. Wax is the most popular pattern material used.
- Sand mix is a refractory slurry consisting of -200 mesh sand, a binder (ethyl silicate or colloidal silica etc.) accelerator (HCl), water.
- First the required shape of the pattern is got by injecting molten wax into a metallic die. After freezing, the pattern is taken out of the die.
- A number of patterns may be attached onto a common sprue with necessary gates, to form a cluster.
- The cluster pattern is dipped in the refractory slurry and taken out. A thin layer of coating is formed on the pattern.
- This process is continued several times (7-8) so that 8-10mm shell thickness is formed.
- Now the shell is heated suddenly at 110-1200oC to remove wax as well as sintering the shell (to harden the shell).
- The sintered shell with the cavity is ready to receive molten metal.
- After casting the metal, the shell is broken and the required castings are separated/cut off from the sprue and gate.
- Wax is collected and reused.
- The castings are then collected for dispatch.
- All types of metals and alloys can be easily cast.
- Mainly Ni alloys, alloy steel, high temperature alloys are cast.
- Surgical instruments, turbine blades, aerospace parts, etc., are produced by this method.
- Process is costly.

Sweep Moulding

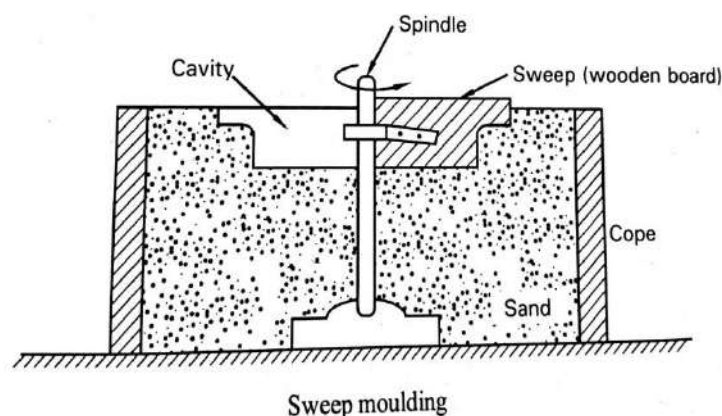

In sweep moulding, the cavity is formed as the pattern sweeps the sand all around the circumference.

A thin wooden piece is attached to the spindle at one edge while the other edge has a contour depending on the desired shape of the casting. (Refer Fig. 5). The spindle is placed at the center of the mould and rotated so that the wooden piece sweeps in the mould box generating the shape of the required casting. Green sand, loam sand or sodium silicate sand

can be used to prepare moulds. The process is used for producing large castings of circular sections and symmetrical shapes.

Full Moulding

- The mould contains pattern along with the sand.
- No cavity is seen in the mould.
- When molten metal is poured into the sprue, mould cavity is created instantaneously.
- The pattern burns off and makes away for the molten to occupy the space left.
- Hence the name full moulding.
- Here polysterene pattern is used.
- Polysterene has very low ash content and burns of easily at molten metal temperature.
- Extremely complex shaped castings can be made by this method.
- Any metal or alloy can be cast.
- Pouring rate of metal is very important in the process.
- Regular moulding sand can be used for moulding.
- Pattern is placed in the mould box and sand is rammed alround.
- The pattern with gates and riser is left in the mould itself.
- Molten metal is poured through the sprue at a rapid rate.
- Pattern burns off, cavity is created in its place and molten metal fills up this, instantaneously.
- Thus mold cavity is created and is filled up with liquid metal at the same time.
- After cooling, the casting is taken out (solidified metal).
- Each time a new pattern must be used, to produce a casting.

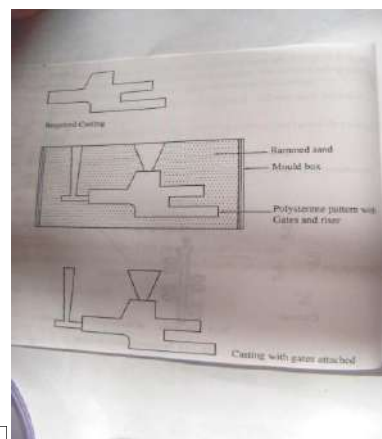
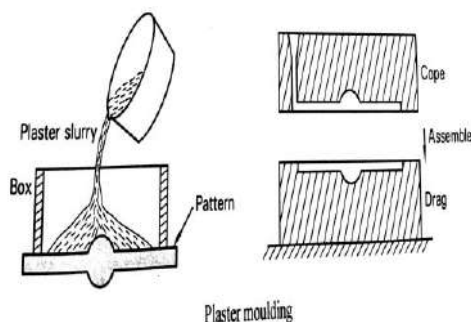

- Good accurate, consistent quality castings can be produced in the mould.
- Very much useful in mass production.
- The molten metal is subjected to gravitational force.
- Suitable for small & medium size castings.
- Section thickness of <math><6\text{mm}</math> can be cast.
- The metal moulds incorporate gating & risering.
- Process is costlier than sand mould.

Gravity die casting or Permanent mould casting

- It is referred to as *Gravity Die Casting* or *Permanent Mould Casting*. The
- process makes use of a metallic mould to produce the casting.
- Two halves of the dies are used to produce the casting.
- The die halves are cleaned well first.
- Then the dies are preheated.
- The dies are coated with a refractory mould coating.
- The die halves are closed and clamped.
- Molten metal is then poured into the cavity via sprue/pouring cup and allowed to solidify under gravity or atmospheric pressure.
- Metal is then allowed to cool.
- After solidification, casting is removed by opening the mould/die halves.
- The molten metal cools faster in metal moulds than in sand moulds.
- Section >6mm thickness can only be cast.

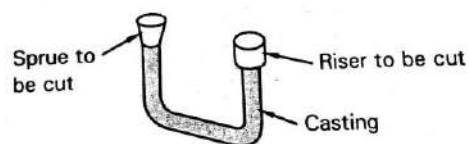
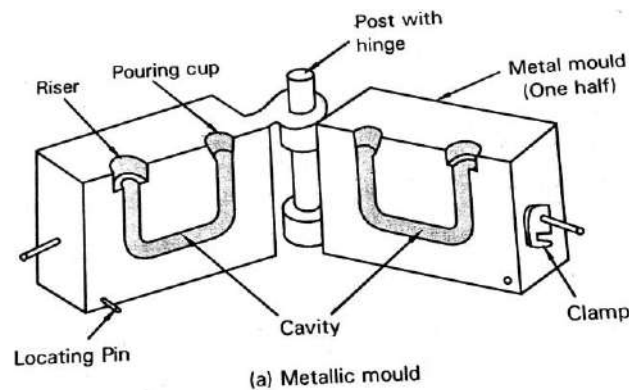

Gravity die casting

- Ex. Piston, carburetor bodies, oil pump bodies, connecting rods, etc.

Pressure die casting

- Here also a permanent mould in two halves is used to produce castings, repeatedly.
- But external pressure is used to force the molten metal into the mould cavity.
- Hence much thinner castings can be produced as compared to gravity castings.
- It can be further classified as *Low Pressure Die Casting (LPDC)* and *High Pressure Die Casting (HPDC)*.

Low Pressure Die Casting (LPDC) process:

- Here a pressure of approximately 1N/mm^2 is applied on the molten metal during solidification.
- Die halves are closed and molten metal is poured into the mould cavity and pressure is applied immediately.
- After few minutes, the die is opened and the casting is removed.

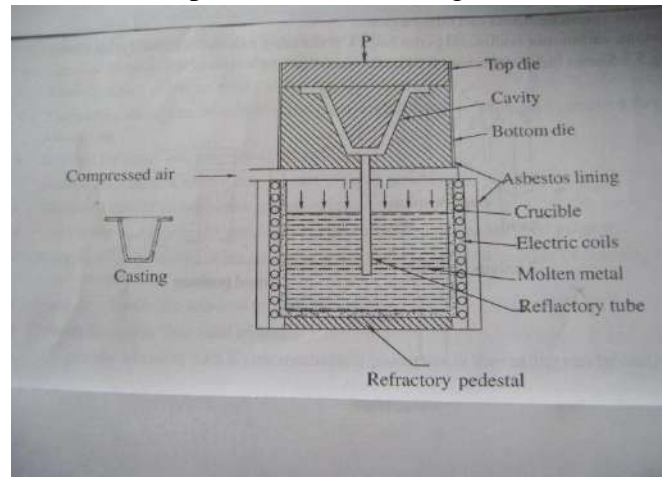
**Construction:**

- Consists of a crucible positioned inside a resistance type electric furnace.
- Metal ingots are placed inside the crucible and current is passed through the coils.
- Temperature of the molten metal is maintained constant.
- The entire crucible and furnace is housed inside a metal chamber.
- The lid of the crucible is closed with asbestos lined hollow plate with an opening for passing air through the plat. The plate has holes extended to the inside of the crucible.
- A refractory tube enters the molten bath and connects the die cavity.
- Whenever compressed air is passed through the opening the molten metal is pushed upwards through the pipe into the die.
- After the metal cools casting is removed from the die.
- Thin castings can be made.

High Pressure Die Casting (HPDC) process

- A pressure of $7\text{-}500\text{ N/mm}^2$ is applied on the molten metal during solidification.
- Very thin and intricate castings can be made.
- Very high mechanical properties, good surface finish castings can be produced.
- Section thickness, 6mm can easily be produced.
- Any metal or alloy can be cast.
- Very large number of castings can be produced in a single die.

High pressure die castings can be classified into:

1. Cold chamber die-casting process (CCDP)

2. Hot chamber die-casting process (HCDP)

- In CCDP, molten metal is poured outside the die chamber and then forced into the die.
- There will be a drop in the metal temperature by the time it reaches the die cavity.
- A separate melting unit is used to prepare the molten metal.
- In HCDP, molten metal is carried through a unit which is submerged in the molten metal itself. And the molten metal is forced into the die cavity. Hence, the metal does not lose any temperature at all.

Cold Chamber die casting process (CCDP)

It consists of a cylinder and a plunger arrangement. One end of the cylinder is connected to the movable die. A fixed die engages the movable die. The movable die and cylinder move together. The cylinder has an opening on the periphery. Through this opening the molten metal is poured inside the cylinder. As and when the plunger moves towards the die, the molten metal is forced into the die with high pressure. The dies are separated after few seconds. By the help of an ejector solidified casting is removed. Process is repeated.

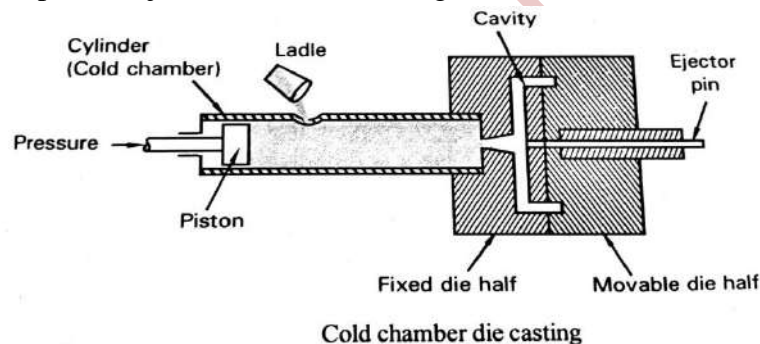

- Dies in closed position. Molten metal poured into the cylinder
 - Plunger pushes the metal into the die out.
 - Movable die and plunger moves out.
 - Ejector pushes the casting out of the die.
 - Dies close and ready for the next casting
- Very high pressure $20\text{-}200\text{ N/mm}^2$ is applied through the plunger.

Hot Chamber die casting process (HCDP)

i) Using compressed air

- It consists of a goose neck chamber housed in a melting pot.
- Melting pot holds liquid metal and is heated by a furnace.
- The goose neck has a nozzle end which connects the die opening.
- The die is closed and the goose neck chamber draws molten metal from the melting pot.
- Now compressed air is allowed into the goose neck chamber.
- This forces molten metal into the die cavity.
- The molten metal solidifies after few seconds.
- The die is opened and the solidified casting is ejected out.
- The die is ready for the next cycle.

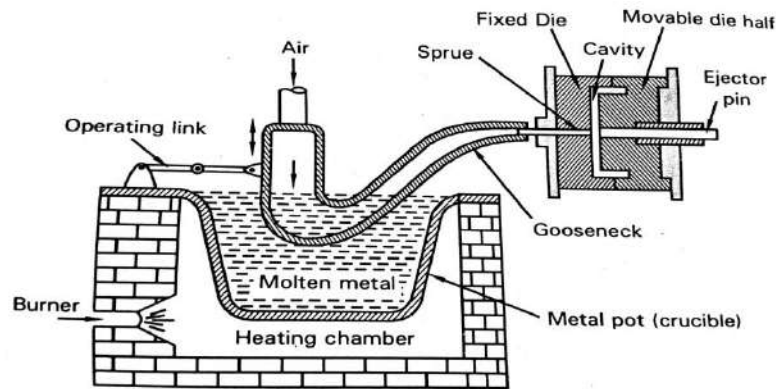

Hot chamber die casting (Goose neck type)

ii. Using a plunger:

- It consists of a melting pot with a goose neck secured on to brick lining.
- The pot is heated from outside.
- A burner is located which supplies flame for heating the pot.
- Molten metal enters the goose neck chamber through the inlet.
- The goose neck portion of the chamber ends as nozzle and connects the opening of the dies (fixed end).
- The die is closed to start with.
- The goose neck chamber draws molten metal from the pot. Goose neck connects the die.
- Now the plunger moves down forcing molten metal into the die cavity. Plunger is withdrawn after few seconds.
- After few seconds the metal solidifies. The die is opened and casting is taken out.
- The die is ready for the next casting.
- Burner keeps the metal at a constant temperature always, in the pot. Refer Fig. 10.

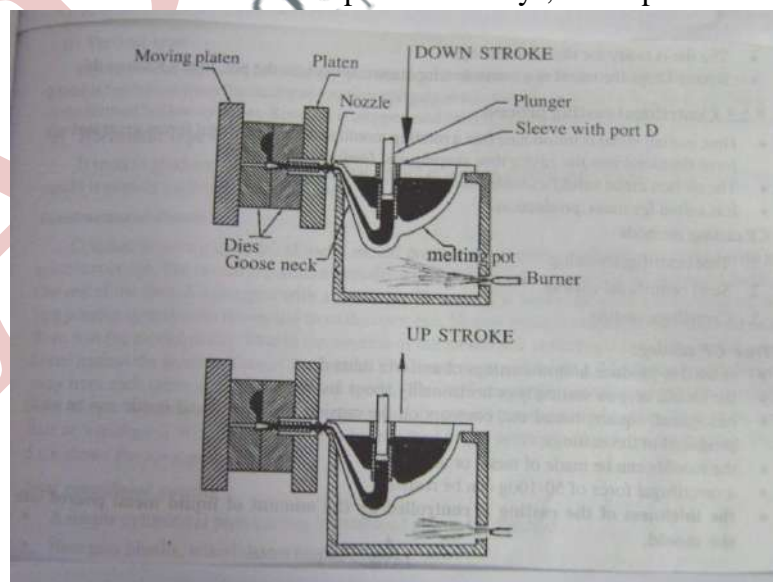

Hot chamber die-casting machine (using plunger)

Continuous casting

Here liquid metal is directly converted into solid form in one stretch to produce billets, bars, structural sections, etc.

It is a continuous casting process in which the operation of pouring, solidification and withdrawal of casting from an open mould are carried out continuously.

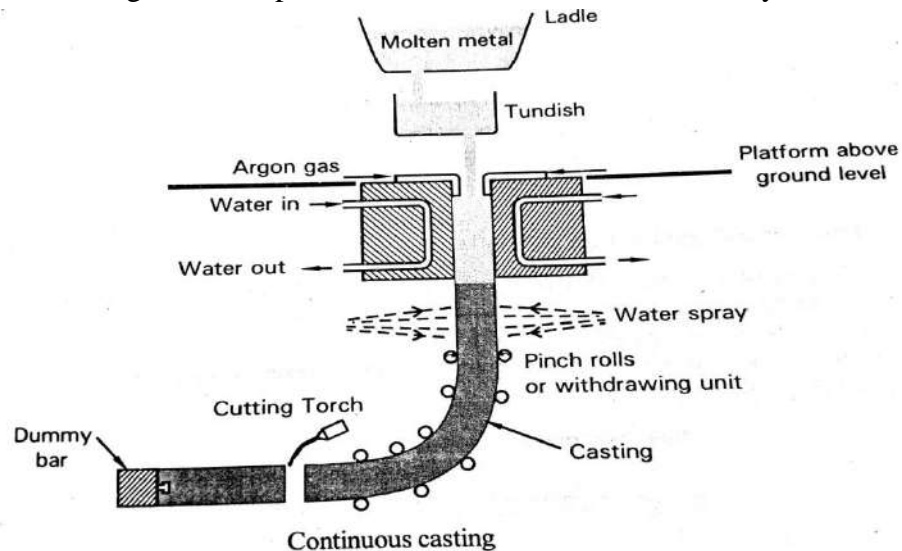

- The molten metal is continuously supplied from the ladle to the intermediate ladle called tundish, through the opening in the tundish; the molten metal is fed into the mould with minimum turbulence and keeping the level at a constant position.
- The mould is usually made of copper or graphite is open at the bottom and is water cooled to extract the heat of the metal causing its solidification. The shape of the mould corresponds to the shape of the desired casting.
- The process is started by placing a dummy bar at the bottom of the mould upon which the first liquid metal falls.
- The molten metal from the tundish enters the mould and takes the shape of the mould. The water cooled mould controls the cooling rate of the metal, so that it solidifies before it leaves the mould.
- The metal after coming out of the mould is further cooled by direct water spray (or water with air) to complete solidification.
- The solidified metal is continuously extracted (along with the dummy bar) by „pinch rolls’, bent and fed horizontally and finally cut to the desired length.

Note: The dummy bar is initially placed at the bottom of the mould to receive the first liquid metal. It is latter disconnected from the casting.

Advantages:

1. No wastage of metal, no riser / no runner / no ingate are required.
2. The casting yield is very high almost 100%.
3. Continuous production of castings can be carried out which is not possible in other processes.
4. Since directional solidification is present, the casting will have superior properties.

5. Grain size can be controlled very easily by controlling the cooling rates.
6. Human skill is almost eliminated.
7. Surface of the casting will be extremely good.
8. The output of the continuous casting can be easily converted to sheet, bar billet et.
9. Complete automation is possible.

Disadvantages:

1. Initial cost of equipment is very high.
2. Close maintenance of the plant is very much desirable.
3. Cost of the product is on the higher side.

Centrifugal casting

Centrifugal casting is a process in which the molten metal is poured and allowed to solidify in revolving mould. The centrifugal force due to the revolving mould holds the molten metal against the mould wall until it solidifies.

The material used for preparing moulds may be cast iron, steel, sand or graphite (for non-ferrous castings). The process is used for making castings of hollow cylindrical shapes. The various centrifugal casting techniques include:

- a. True centrifugal casting
- b. Semi-centrifugal casting and
- c. Centrifuge casting.

a. True Centrifugal Casting:

True centrifugal casting is used to produce parts that are symmetrical about the axis like that of pipes, tubes, bushings, liners and rings. The outside shape of the casting can be round, octagonal, hexagonal, etc. but the inside shape perfectly (theoretically) round due to radially symmetric forces. This eliminates the need for cores for producing hollow castings.

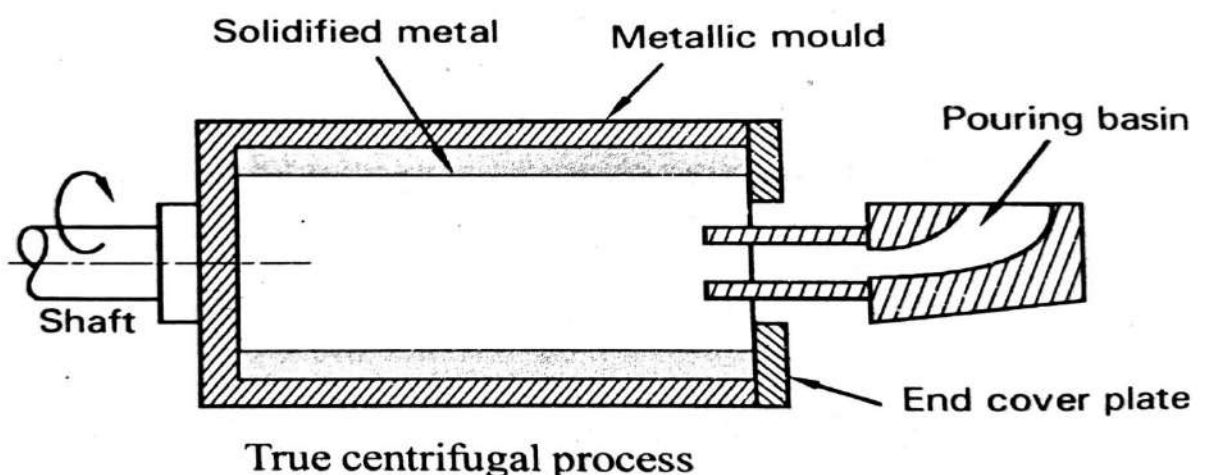

Process:

1. The mould of the desired shape is prepared with metal and the walls are coated with a refractory ceramic coating.
2. The mould is rotated about its axis at high speed in the range of 300-3000 rpm. Measured quantity of molten metal is poured into the rotating mould.
3. The centrifugal force of the rotating mould throws the liquid metal towards the mould wall and holds the molten until it solidifies.
4. The casting cools and solidifies from its inner surface towards the axis of rotation of the mould thereby promoting directional solidification.
5. The thickness of casting obtained can be controlled by the amount of liquid metal being poured.

Note: The mould can be rotated horizontally or vertically. When the mould is rotated about a *horizontal axis*, a true cylindrical inside surface is achieved, if rotated on a *vertical axis*; a parabolic inside surface is achieved.

Cores and gating / risering systems are not required for this process.

b. Semi Centrifugal Casting

- It is a process to produce solid castings and hence requires a core to produce hollow cavities.
- A simple cylindrical pipe casting is produced in true CF method.
- Gear blanks, wheels, pulleys are produced.
- CF force is used to force the molten metal to get the shape in the casting.
- A speed of 300-500 rpm is employed.
- Cope and drag moulds are made in sand and fixed on to the casting machine.
- Core is also assembled.
- The riser extended to the top surface acts as pouring basin.
- The mould is kept rotating and molten metal is poured
- Molten metal gets thrown outward forcing it against the mould wall.
- Molten metal solidifies and casting shape is formed.
- After cooling, casting is taken out.
- A fresh mould box is kept and the process is repeated.

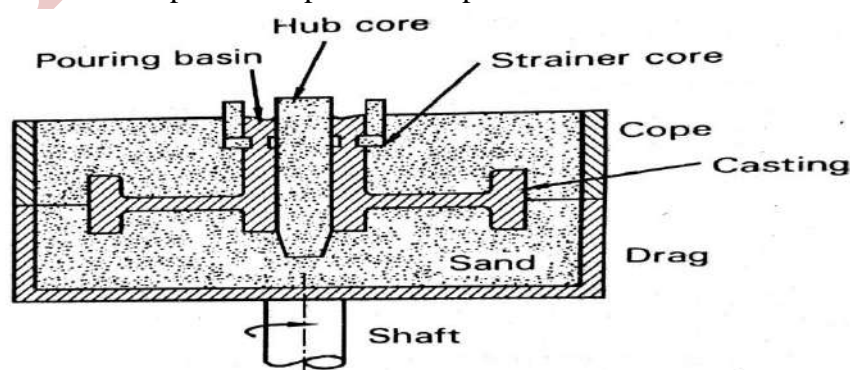

Semi-centrifugal process

Centrifugal Casting

- A number of castings whose axis is away from the axis of rotation can be made each time.
- Any casting shape that can be created in the sand mould can be formed in this process.
- A number of mould impressions are grouped around a central sprue and subjected to CF force due to rotation.
- Small castings are done by this method.

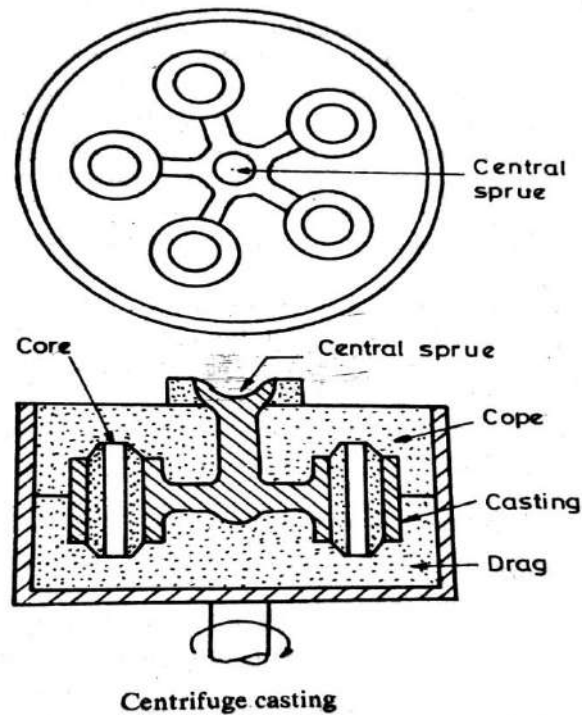

Squeeze casting

Squeeze casting or squeeze forming or liquid metal forging is a combination of casting and forging process. Fig. shows the sequence of operations involved in the process.

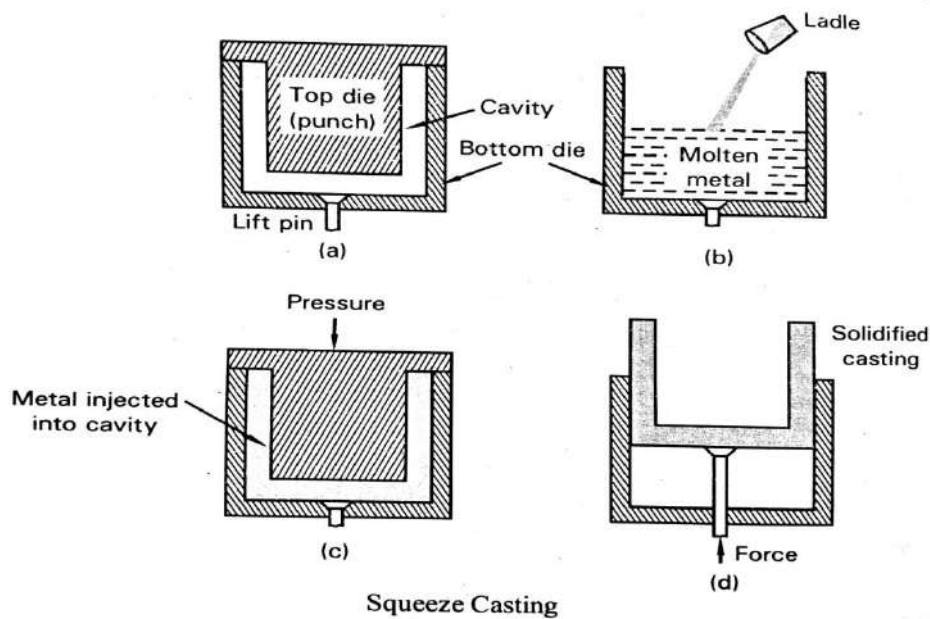
**Process:**

1. The process makes use of two dies: bottom die and top die, cast and machined in such a way that upon mating leaves a cavity similar to the shape of the desired casting.
2. The bottom die is preheated to around 200-250°C with the help of torch and sprayed by a water based graphite lubricant to facilitate easy removal of casting after solidification.
3. Measured quantity of molten metal is poured into the bottom die as shown. As the metal starts solidifying, pressure is applied to the top die causing it to move rapidly towards the bottom die. This causes the molten metal to get squeezed and fill the mould cavity.
4. The squeezing pressure is applied until solidification is completed.
5. The casting is ejected by operating the lift pin provided in the bottom die, and the die is made ready for the next cycle.

Squeeze casting is commonly used for casting aluminium and magnesium alloys. Cores can be used in this process to produce holes.

Slush casting

- Castings with external features having aesthetic value are made by this technique.
- Castings will be hollow inside and wall thickness may be non-uniform.
- Core is not required for the purpose.
- Ex. Lamp posts, statues, toys, etc are produced by this method.
- Molten metal is poured into the metal mould.
- After few seconds the mould is inverted and the molten metal is drained out into a container.
- A thin layer of solidified metal is formed in the mould.
- The mould is opened.
- The thin layered hollow casting is taken out.

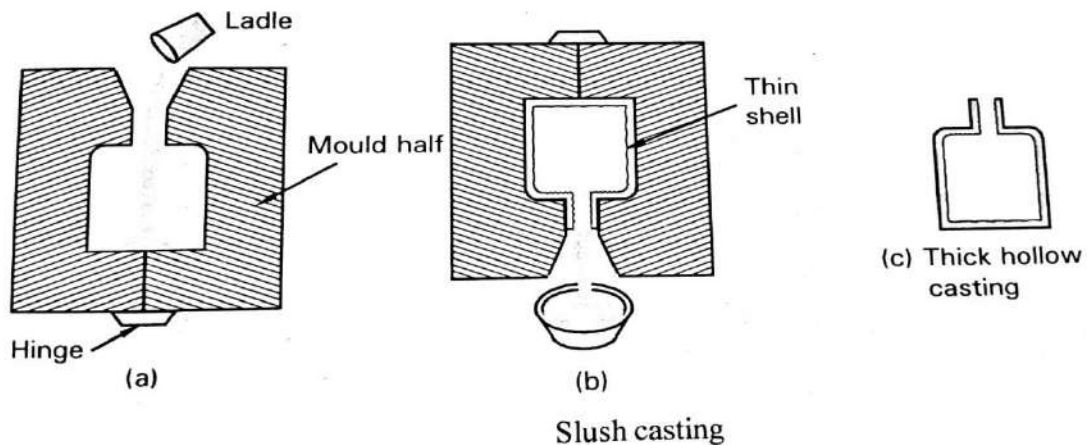

Thixocasting process

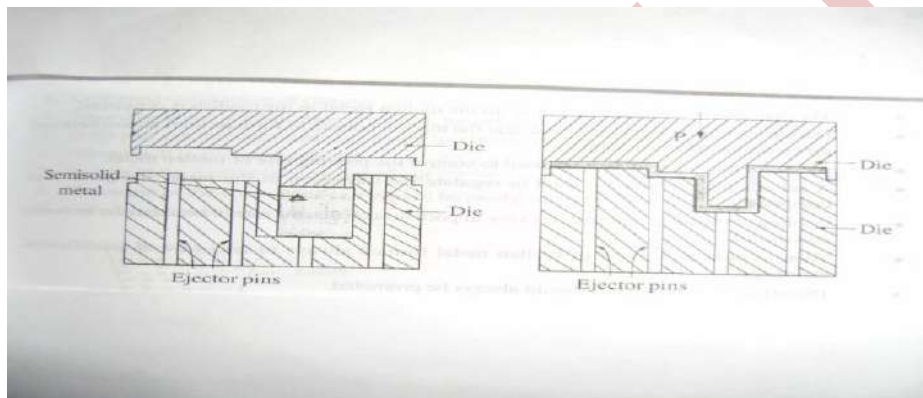

In this process, semi solid metal is subjected to compressive force inside a die and the metal, is shaped as required.

Principle:

A known quantity of metal is heated in a furnace to its softening point then subjected to external force when kept inside a die cavity. Since the metal is subjected to squeezing action, when it is in plastic state or semi-solid state, it is referred as “*Thixocasting*”.

Process:

- The metal pieces are kept in a furnace and maintained at a known temperature.
- When the metal reaches to a pasty zone as indicated by an indicator, semi-solid metal is transferred into the cavity and forced between two dies.
- The dies used for the purpose are capable of withstanding wear & tear and high temperature.
- The semi-solid metals cool very fast and gets solidified. The component is withdrawn, the casting is ejected out. Fig shows the details.

Metals and alloys are converted to liquid state using an equipment (a refractory lined metallic shell wherein this conversion takes place) called “*furnace*”.

The source of heat provided to the furnace for the conversion of solid to liquid is called as “*melting furnace*”.

Furnaces are selected based on the type of metal to be melted, quantity, fuel used and quality of metal required, etc.

CLASSIFICATION OF FURNACES

The melting furnaces used for melting various ferrous and non-ferrous metals and alloys can be classified based on:

| Fuel | Metal melted | Furnace used |
|----------------------|---|--|
| Coke (solid lump) | <ul style="list-style-type: none"> ● Cast iron ● Non-ferrous alloys | <ul style="list-style-type: none"> ➤ Cupola ➤ Crucible/Pit furnace |
| Oil (liquid) | <ul style="list-style-type: none"> ❖ Non-ferrous alloys ❖ Iron, steel | <ul style="list-style-type: none"> ▪ Crucible (pit) furnace ▪ Open hearth |
| Gas (gaseous) | <ul style="list-style-type: none"> ▪ Non-ferrous alloys ▪ Iron, steel | <ul style="list-style-type: none"> ❖ Crucible (pit) furnace ❖ Open hearth |
| Electricity | <ul style="list-style-type: none"> ○ Steel, cast iron ○ Non-ferrous alloys ○ Iron, steel | <ul style="list-style-type: none"> ● Electric Arc furnace (Direct arc) ● Resistance furnace ● Induction furnace |

COKE FIRED FURNACE

In this type of furnace, the crucible kept on the pedestal (refractory support) charged with the ingot, coke lumps are packed around the crucible and ignited. Once it starts burning, blower is switched on, and then the coke is charged slowly, till the coke reaches the level of crucible. A lid is placed on the crucible and the blower is kept full blast. Metal starts melting and once it reaches the desired temperature blower is switched off. Crucible is taken out, and the molten metal is treated and poured.

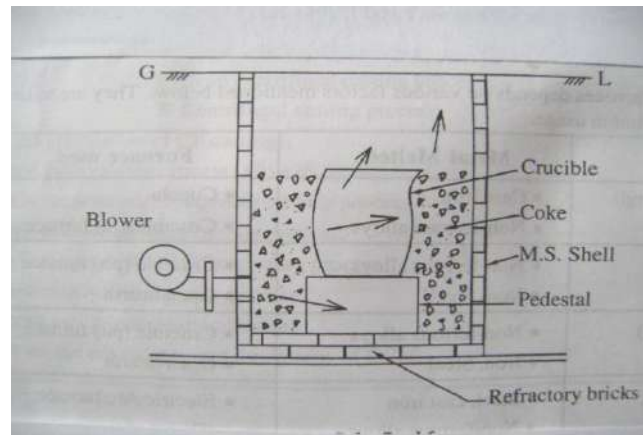

Coke fired furnace

OIL FIRED FURNACE

In this type of furnace, the crucible kept on the pedestal (refractory support) charged with the ingot. A burner is situated at the bottom on one side. Valves are provided to control the amount of air and oil supplied to the burner, so that the flames can be controlled. The oil from the burner is ignited and the desired flame is controlled by valves. After the metal melts and attains the desired super heat, the crucible is taken out and the molten metal is treated and poured.

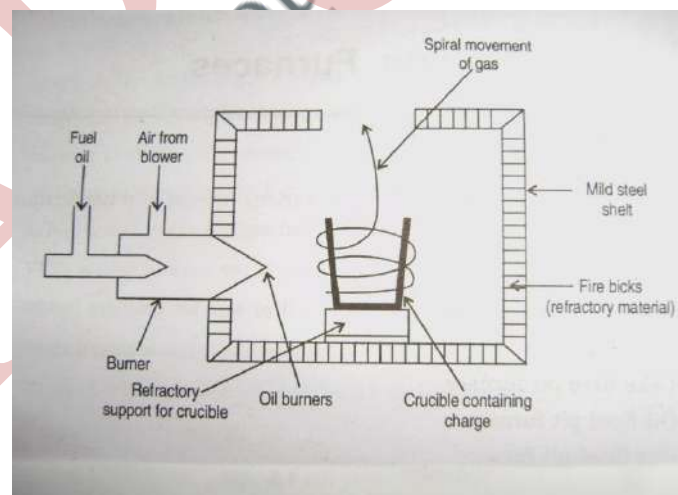

Oil fired furnace

GAS FIRED FURNACE

Fire is created at the bottom using waste/coke/wood, etc. Gas is blown through the burner. This will create a flame and heats the inside of the lining. The burner is switched off and the crucible with ingots is placed. The burner is switched on. Flame will sweep round the crucible and the flame is used to melting. Once the metal reaches the desired temperature, the burner is switched off and the crucible is taken out and the molten metal is treated and poured.

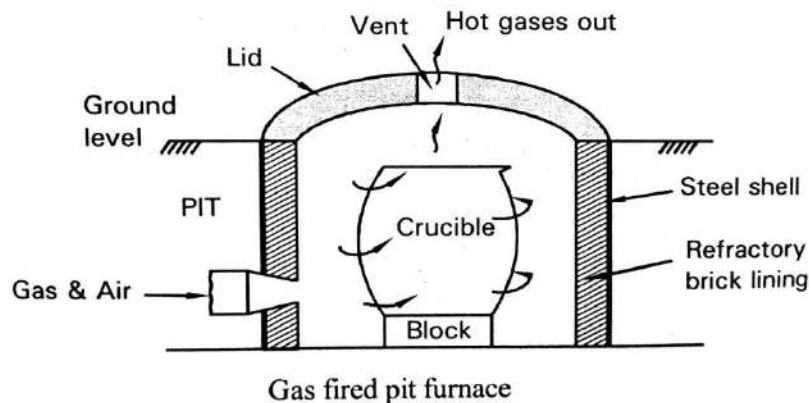

RESISTANCE FURNACE

Fig. shows the indirect type of resistance furnace. It consists of current carrying coils inside the refractory bricks. The crucible with ingots charged is kept in the furnace on the pedestal and the lid is closed. Current is switched on. The temperature of the furnace is controlled by a temperature controller. The melting starts slowly. After completion of melting, the lid is opened; crucible is taken out for pouring. Heating takes place due to the resistance offered by the coil material on the principle of I^2Rt . This type of furnace is normally used for melting non-ferrous alloys.

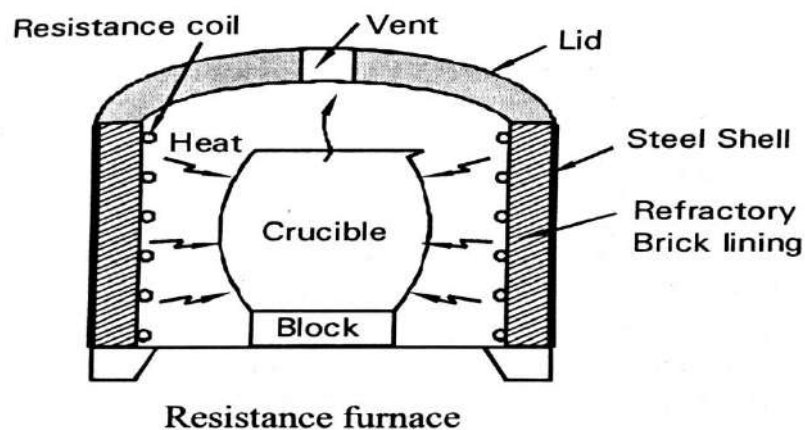

Principle of working:

Due to the flow of current in the coil, the metal of the coil offers resistance and heat is generated according to the formula:

$$Q = I^2 R t \text{ joules}$$

where, Q = heat generated in joules

I = flow of current in amps

R = resistance of the coil in ohms

t = time of current flow in seconds

The heat generated from the coil is utilized to heat the metal in the crucible to melt. Very cleaned molten metal is easily obtained. Controlling is very easy.

INDUCTION FURNACE (IF)

It is the most popular furnace for carrying out melting operation with simplicity. Good quality of melt can be obtained. It works on the principle of induced *emf* as in the case of transformer. Molten metal acts as the secondary and the current carrying conductor acts as the primary.

Principle of working

- Induction furnace works on the transformer principle
- Water cooled copper coil carrying current acts as the primary
- The metallic charge in the crucible acts as secondary
- Current induced in the charge is by electromagnetic induction
- The charge offers resistance to the flow of induced secondary current
- Due to this, heat is developed and the charge starts melting
- Induction furnace is capable of melting all types of metals and alloys from small quantities to large quantities (25 kg to 10T) very easily, conveniently and quickly.
- Due to the induced emf caused, stirring of molten metal in the melting process is the special feature, thereby gives excellent homogeneity in the composition
- The furnace houses a crucible inside copper coils.
- The crucible is formed by ramming refractory grains and sintering it
- A sheet of mica or asbestos separates the coil and the refractory
- The outer shell of the furnace is made of mild steel

Types of Induction Furnace

The types of induction furnace are:

- Core type I.F.
- Core less type I.F.

In the first type the coils are surrounded by the molten metal.

In the second type the coils surround the molten metal.

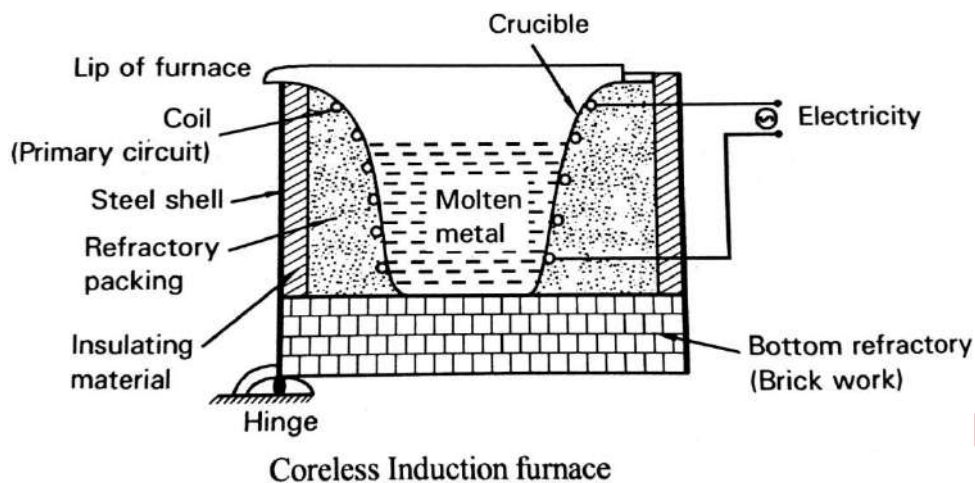
Coreless type I.F.*The constructional features of coreless type I.F.*

- The furnace consists of an outer cylinder steel shell and is hinged at the bottom front side to facilitate tilting for pouring.
- The inner surface of the shell is covered with mica or asbestos and the bottom surface is covered with refractory bricks.
- Next to the insulation layer hollow copper tube coils are present for the entire height of the shell.
- These tubes carry current and are water cooled.
- A layer of insulation is provided to the coils.
- Compacted ramming refractory packing is provided above the bricks to form the base.
- A thin steel (shell) former is provided on the top of the base.
- The annular space between the shell and the coil is rammed with the ramming mass.
- The steel former holds the ramming mass surrounding it.
- The top of the furnace front ends in the form of lip or spout to facilitate the metal to flow.
- The inside portion of the former determines the furnace capacity.

Working principle

- The furnace works on the principle of a transformer in which the copper coils acts as primary and the charge (scrap) as secondary.
- Sintering consists of passing low amperage current through the coil for several hours.
- Due to this, emf is induced in the former and gets heated up.
- The former becomes red hot and this starts heating the ramming mass and sinters.
- Slowly layer by layer of refractory mass gets sintered.
- The current is slowly increased and heating is continued for several hours.
- Loose thin scrap is slowly charged into the crucible.
- The scrap slowly starts melting and liquid metal pool is formed.
- After some time molten metal starts stirring and the stirring action is due to the eddy

current induced in the metal which will be flowing opposite to the direction of main current.

- The stirring action or churning ensures homogeneous molten metal.
- Necessary alloying elements can be easily be added.
- The charge needs to be properly selected, since slag removal is difficult due to stirring action.

Core type of induction furnace

Here the oil is surrounded by the metal. The principal of working is the same as above. The furnace is not very popularly used in practice.

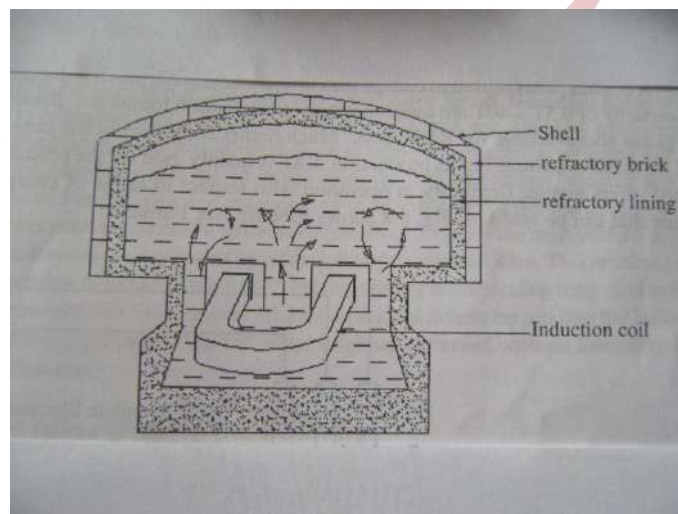

Core type induction furnace

ELECTRIC ARC FURNACE

It is a versatile furnace used to melt mainly steel. It makes use of electric current to generate the arc in the metal. The arc heats and melts the charge. Melting using electricity as a source of energy is more common. This is because electric furnace provides more flexibility and cleanliness in operation.

These are suitable for the production of high quality of steels. There are two types of electric arc furnaces:

1. Direct Arc Furnace
2. Indirect Arc Furnace

Direct Arc Furnace

It consists of a steel shell, cylindrical in shape with a spherical or flat base, which is mounted on rollers to enable tilting the furnace to tap out the molten metal. The shell is lined with fire bricks. The roof is made of silica bricks. The hearth is lined with basic material

such as magnesite bricks. The charging may be done either from the top or from the side. In top charging type the roof can be swung along with electrodes, while in side charging type, a side door is provided. A tapping hole with spout is provided to tap out the molten metal.

Generally, three electrodes are arranged in a triangular pattern. These electrodes can be raised or lowered by mechanical or other automatic means. This helps in setting the arc and to maintain the desired temperature. The electric current (three phase) is led into the furnace through the three carbon or graphite electrodes. The arc is struck between the electrodes and the charge. The arc gives out high temperature (about 2000 to 5000°C) which melts the charge below the electrodes. Gradually, a pool of molten metal forms below the electrodes, which in turn melts the remaining metal in the furnace.

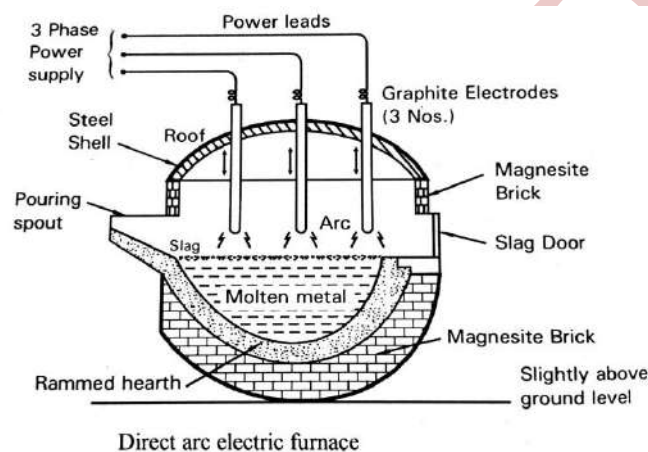

The electrodes should have high electrical and low thermal conductivity, good refractoriness and resistance to oxidation or chemical reaction also should have good strength at high temperature. Usually graphite or amorphous carbon is used as electrode material.

Then excess slag is removed from the slag door. The molten metal is then tapped into the ladle and taken for teeming.

Indirect Arc Furnace

Fig. shows an indirect arc electric furnace used for melting small quantities of ferrous and non-ferrous metals.

The furnace consists of a cylindrical or barrel shaped shell lined with a refractory material. The shell is mounted on rollers and can be tilted through 180°. This facilitates for easy pouring. Also, the rollers provide rocking action to the furnace that speeds the melting rate.

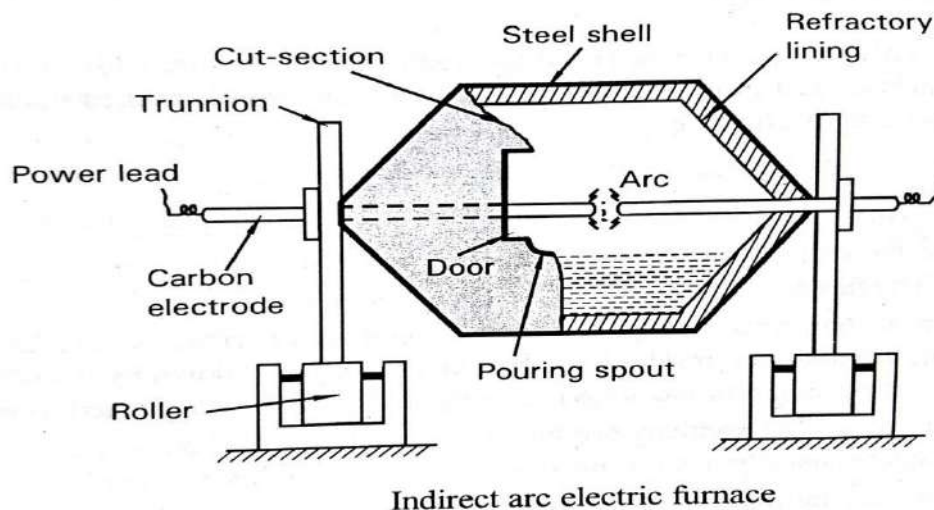

Two carbon electrodes are mounted along the horizontal axis and can be automatically adjusted for maintaining proper arc column. A charging door and pouring spout serve their purpose.

Working

- The ingot steel scrap and alloy metals and fluxing agents are charged into the furnace.
- On supplying the necessary current and voltage, an arc is struck between the two non-consumable carbon electrodes. The electrodes are brought closer together and maintained, so that the arc remains between them.
- The charge melts by radiation from the heat produced by the arc and also by conduction from the heat absorbed by the refractory lining.
- Once the metal melts, the furnace is rotated (set to rock to and fro). This helps the refractory lining to get heated up and also the molten metal exposed to a larger area of the heated lining. Rocking stirs the molten metal homogeneously.
- When the liquid metal reaches the desired temperature, the furnace is tilted mechanically and the metal is tapped in ladles and poured into the moulds.

CUPOLA FURNACE

- Cupola is a vertical cylindrical shape type furnace.
- It works on counter current principle.
- Charge materials will be descending downwards. Flue gases will be ascending upwards.
- Thereby exchange of heat between the rising gases and the descending charge takes place efficiently.
- Coke lumps are used as the fuel.
- Lime stone is used as flux material.
- Coke, lime stone and metal charge are charged into the cupola in the same sequence with a definite ratio.

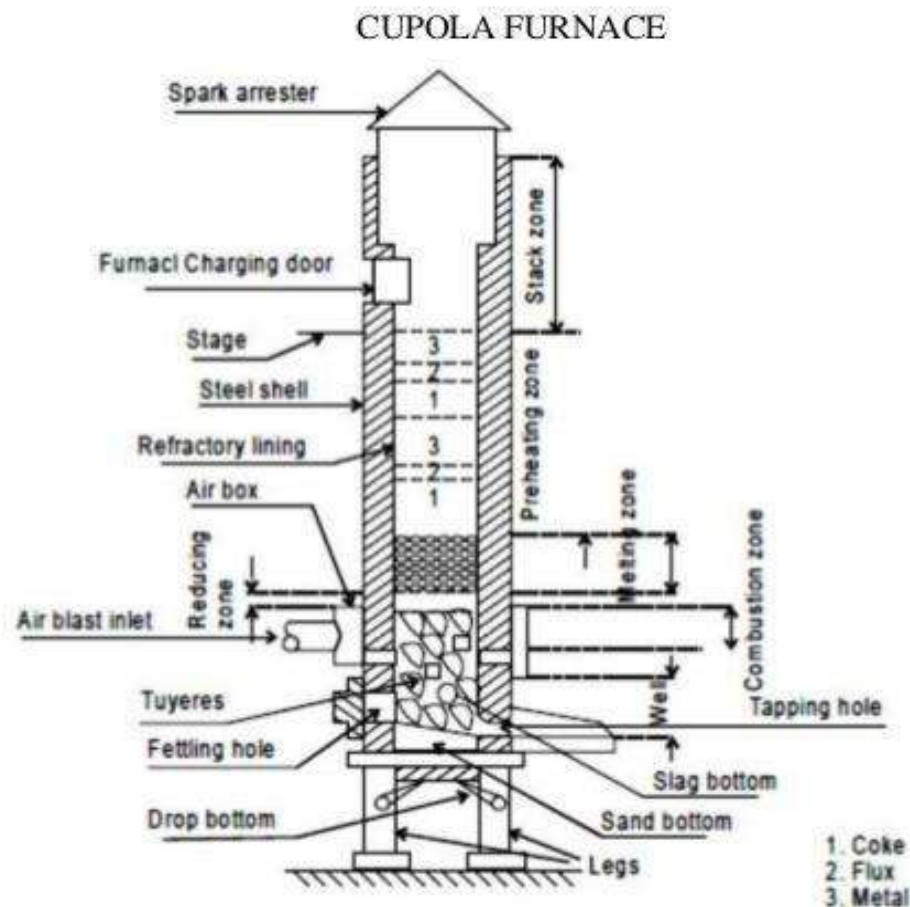

Construction

- It consists of a cylindrical steel shell of large **H/D** (height to diameter) ratio supported on legs at the bottom.
- It has two semi-circular steel doors hinged at the bottom and it can be opened or closed as required.
- The inside shell is lined with fire clay refractory bricks.
- The entire structure is placed vertically on a rigid concrete base.
- When the doors are closed and clamped the furnace bottom is prepared by ramming sand mixed with fire clay on top of the door.
- Immediately above this, an opening is provided on the circumference of the shell and is called **metal hole**.
- A small channel is provided corresponding to this using steel plate and refractory material is called **metal spout**.
- Through this spout, molten metal is drawn from the furnace.
- Opposite to the metal spout, another hole is provided in the shell to tap the slag.
- Slightly above this a wind box is provided around the shell. Numbers of holes are provided in the steel shell (covered by the wind box).
- These are called **tuyers**.

- The wind box is connected to a **blower** through which the air is made to enter.
- This blast of air enters the inside portion of the lined shell radially inwards.
- This air provides necessary oxygen for combustion process.
- Far above the wind box a charging platform is provided to facilitate storing of charges and movement of operators.
- Close to the platform, a charging door is provided with a hood or spark arrestor.
- This ensures arresting of the sparks emanating from the furnace.
- To facilitate easy operation and reduce the projection of furnace above the ground, a pit of 3-4 feet is dug below the ground to house the furnace.
- The height of the coke inside the cupola from bottom and up to the wind box is referred as **coke bed height**.

Working

a. *Starting the Cupola*

- Before starting the cupola, the bottom doors are closed and locked.
- On this door, sand bed is prepared and the metal spout is closed with a clay slug.
- Burning wood splinters are dropped from the door of the furnace. Slowly wood pieces starts burning and some more wooden pieces are dropped.
- When this also catches fire, coke pieces are dropped from top.
- The coke pieces slowly catches fire, ignite and become red hot.

b. *Charging cupola*

- Now coke lumps are dropped continuously into the furnace up to the **wind box** level.
- The wind blast is slowly turned on supplying air for combustion.
- This results in the burning of coke pieces continuously.
- Now alternate layers of **coke, flux (lime stone) and metal (iron)** charges are dumped inside the furnace till the inside portion of the furnace is filled up to the charging door.
- The blast of air is increased and kept at maximum.
- The air enters the furnace through **tuyers**.
- Coke not only acts as fuel but also act as burden until melting occurs.
- Lime stone act as flux and protects the metal against excessive oxidation.

c. *Melting*

- As the temperature inside the furnace reach very high value the coke burns off, lime stone fuses and metal charge melts and trickles of liquid metal starts dropping down to bottom of the furnace.
- Molten metal collects at the bottom and accumulates.
- The external charging of the furnace is continued.
- Just above the tuyers in the wind box, maximum temperature is attained and this zone is referred to as **superheating zone**.
- Here the molten is heated to above its melting point, hence referred to as **super heat**.
- Above this zone, the actual melting of metal takes place.

- This zone is called **melting zone**. This zone is approximately 2 times that of super heat zone.
- Above this zone and upto the charging door is the **preheating zone**. Here the metal charge, lime and coke will be preheated.
- Above the door and upto the hood region is the **stack zone**. Only flue gases escapes through this zone.
- As the cold charges are moving downwards the hot flue gases will be ascending.
- This results in very good heat exchange between the two. Charges gain heat and the flue gases lose heat.
- This phenomenon is referred to as **Counter Current Principle**.
- The charging of cupola is continued and the molten metal gets accumulated and the slag formed also accumulates above the molten metal due to density difference.

d. Tapping slag and molten metal

- The slag door is kept open always and when the slag level inside the furnace reaches the slag spout, slag starts coming out continuously.
- This is an indication that the molten metal is ready for tapping.
- This should happen at around 15 minutes after full blast of air to the furnace.
- The bottle green color of slag also suggest that the molten metal quality is good.
- Now the metal spout is opened and molten metal is tapped into the ladle and collected.
- The furnace operation is continued and the molten metal is continuously tapped.
- The furnace is stopped by stopping charging.

e. Dropping down the bottom

- After tapping the molten metal completely from the furnace, the bottom doors are dropped down.
- The slag drops out of the furnace.
- After cooling, the necessary patchwork of lining is done before the next melting operation.
- The ratio of **coke : metal** is referred to as **coke to metal ratio**, for a good coke it should be anywhere between **1:8 to 1:10** by weight.
- The percentage of **lime stone** is around 5-7% of the metal charge.
- Inside Lined diameter of cupola determines the **melting capacity** of the cupola.
- It may vary from approximately 68 to 275 cm.
- Cupola is specified by the **quantity of molten metal** that can be melted per hour.
Example: 10 tons / hour, means 10 tons of cast iron is melted in 1 hour.
- Cupola is used to produce **cast iron**.
- Cupola is the most popular and widely used furnace in a **foundry**.

ZONES IN CUPOLA

The various zones in a cupola are shown in fig.

The height of the furnace can be divided into various zones for study purpose and observe how the melting process is taking place.

a. Well Zone

It is the portion situated between the rammed sand bottom and just below the bottom edge of the tuyers. The molten metal is occupied in this zone.

b. Combustion Zone

The combustion zone or oxidizing zone is situated from the bottom edge of the tuyers. In this zone where rapid combustion takes place due to which a lot of heat is generated in the furnace. The temperature in this zone varies from 1550°C – 1850°C.

c. Reduction Zone

Reduction zone or protection zone is the portion located from the top of the combustion zone to the top of coke bed. In this zone, some of hot CO₂ gas moving upward through the hot coke gets reduced to CO. In other words, reduction of CO₂ to CO occurs in this zone. Due to reduction, the temperature reduces to around 1200°C in this zone.

d. Preheating zone

The portion occupied from the top surface of the melting zone to the charging door is called “preheating zone”. The hot gases rising upwards from the combustion and reducing zone gives its heat to the charge before passing out of the furnace. Thus the charge is preheated before descending downwards.

MODULE-3

SOLIDIFICATION & NON FERROUS FOUNDRY PRACTICE

3.1 INTRODUCTION TO SOLIDIFICATION

Solidification is the process by which substance undergoes phase transformation from liquid state to solid state. Water converting to ice is a simple example of solidification process. In a casting process, as the molten metal (liquid) is poured into the mould cavity, it begins to cool. When the temperature drops below the freezing point (melting point) of the material, solidification starts.

As known, all metals shrink during change of phase from liquid to solid state. However different metals at different rates and as such proper understanding of the solidification mechanism are essential to prevent defects due to shrinkage of metal. Further, during solidification, the atoms in the material are re-arranged leading to change in the microstructure of the material. The change in the microstructure results in changes in the properties of the material like strength, toughness, ductility, etc. By controlling the solidification process suitably, the microstructure, and hence the properties of the material can be altered as desired.

3.2 NUCLEATION

When a liquid cools below its freezing point (melting point), it starts to solidify, and the atoms of the liquid metal begin to bond together forming a very small sized crystal called nuclei. This process takes place at several locations as shown in figure 3.1 (a).

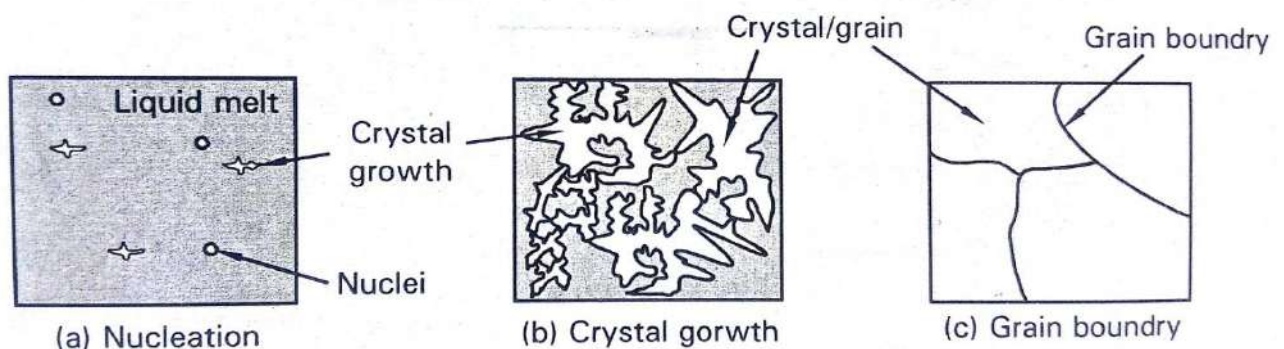

Figure 3.1

The formation of new crystals is known as nucleation, and the point where it occurs is the nucleation point. As the solidification progresses, the crystal increase in size by the progressive addition of atoms and grow until they impinge upon adjacent growing crystal. Crystal growth continues in three dimensions forming a tree like appearance known as dendrites. Refer figure 3.1 (b). The dendrites grow in different directions in each crystal and finally when one dendrite impinges upon the adjacent growing dendrite, a grain boundary is formed as shown in figure 3.1(c). The crystal growth ceases when all the available liquid

metal has solidified.

Types of Nucleation

It is observed that nucleation is helped by the presence of foreign elements or impurities present in the molten metal. Depending on the role of these foreign elements, nucleation is classified into types: Homogeneous nucleation and Heterogeneous nucleation.

When nucleation takes place in the liquid metal without the help of any impurities, then it is known as homogeneous nucleation or self-nucleation. Nucleation based on this mechanism takes place in pure liquid metals only.

On the other hand, when nucleation takes place with the help of impurities, it is known as heterogeneous nucleation. Impurities can be in the form of sand particles, alloy additions, oxides, or even the surface of the mould wall. Thus in the usual casting process, nucleation is heterogeneous.

3.3 SOLIDIFICATION VARIABLES

The solidification process by which a liquid metal freezes in a mould plays a crucial role, because different solidification conditions give rise to different microstructures and hence the properties of the as-cast alloy. The variables affecting the solidification behavior of a casting include:

1) The type or composition of casting alloy

An alloy consists of a base metal to which other elements are added to obtain favourable properties. When an element is added to the base metal, it significantly alters the solidification process. This is because, an alloy freezes over a range* of temperatures. Thus proper control of alloying elements promotes constitutional supercooling[^] and further the additional use of inoculating agents promotes heterogeneous nucleation resulting in fine grained structures in the cast metal.

2) Thermal properties of both the alloy and the moulding material & cooling rate

The heat released during solidification is very large, and as such it must be extracted quickly. The higher the melting point and thermal conductivity of materials used in casting process, the larger is the latent heat (energy released/absorbed) of fusion.

** Pure metals freezes (solidifies) at a constant temperature.*

A Constitutional supercooling, which occurs during solidification, is due to compositional changes, and results in cooling a liquid below the freezing point ahead of the solid—liquid interface.

Inoculation refers to the introduction of another metal into the melt in order to influence the solidification process or structural formation in the casting in a specific way.

Further, the heat extracted per unit time, which is defined as the cooling rate depends mainly on the mould material and the air gap formed at the metal mould interface. High

cooling rate promotes directional solidification at a faster rate with finer grains, while low cooling rate exhibits larger grains. It is important to note that the grain size affects the strength and hardness of the casting. Also, metallic moulds produce higher cooling rate than a sand mould under the same operating conditions.

3) Mould thickness and shape

The thickness of mould influences solidification time (or heat removal rate). In case of sand moulds, heat removal rates are increased by a decrease in mould thickness below a certain critical thickness. However, for the same thickness, solidification is faster in metallic moulds.

4) Chills, Gating, and other Casting design factors

Solidification takes place at a certain rate relative to the thickness of the casting. A casting should be designed to achieve controlled progressive directional solidification so that it becomes free from solidification related defects. Location of gates and risers, use of chills and other means for controlling the freezing process must be adopted suitably for complete solidification to take place.

5) Pouring temperature

The pouring temperature of the molten metal must be higher than the solidification temperature of the metal. This will help the molten metal to flow into all regions of the mould before solidifying and overcomes the solidification related defects. However the temperature of the melt must not be very high, as this might saturate the gases resulting in the formation of oxides. Also the molten metal at high temperature has the ability to penetrate into the surface of the mould material.

3.4 DIRECTIONAL SOLIDIFICATION & ITS NEED IN CASTING

As the molten metal cools and solidifies in the mould, it shrinks or contracts in volume. Due to varying sections of the cast part and different rates of heat loss to adjoining mould walls, some portion of the molten metal tends to solidify more quickly resulting in voids and cavities than other portions. These voids must be filled with the incoming liquid metal from the feeder head (riser). Hence the casting must be so designed with respect to the feeding system such that the part of the mould that is farthest from the feeder head must solidify first and then proceed through the casting towards the feeder head. The solidification which is made to occur in this particular direction is known as Directional Solidification.

Directional solidification can be described as the solidification of molten metal taking place in such a manner that liquid feed metal is always available for that portion of the metal that is just solidifying. It can also be described as the solidification of molten metal taking place progressively from the thinnest part, which solidifies first, and towards the feeder head (riser), which solidifies last.

Note: Directional solidification and Progressive solidification (parallel solidification) are the two types of solidification in castings and hence not to be confused with each other. Although these processes share some common traits, the difference lies in that, in progressive solidification, the cooling and solidifying process begins at the walls of the casting and works

its way inward. With directional solidification, the process of solidification begins at the bottom of the casting and works its way to the top.

3.4.1 Methods/Factors Controlling Directional Solidification:

The various methods of directionally solidifying a molten metal and hence to obtain a sound casting is listed and discussed as follows:

- Proper design and positioning of the gates and risers.
- Use of insulating pads and sleeves for risers.
- Use of chills in the mould
- Incorporating blind riser, and
- Use of exothermic riser compounds

a) Proper design and positioning of the gates and risers.

The shape of the riser must be such that it must lose minimum heat keeping the metal in the molten state. This can be met with a spherical shaped riser, however its incorporation in the mould is difficult. The next best shape is cylinder sand than a square.

Cylindrical riser is the commonly used and it must be at least 15 to 20% larger in diameter than the section it is required to feed. The riser height is usually 1.5 times greater than its diameter. To increase volume to surface area ratio, the bottom of the cylindrical riser can be shaped as hemisphere. The riser must be positioned suitably so that solidification is directional from the casting extremities towards the riser.

(b) Use of insulating pads and sleeves for risers:

The sides of the riser are insulated with sleeves made from suitable materials so as to achieve lower solidification rate in the riser. This enhances better feeding of the casting. Sleeves made from plaster of Paris are used for non-ferrous castings, while pearlite sleeves or fireclay sawdust sleeves are used for ferrous castings. Cellulose materials like rice hulls are also used. Insulating pads can also be employed in various parts of the mould to decrease the cooling rate in thin sections so as to promote directional solidification.

(c) Use of chills in the mould:

A chill is a metallic object of suitable shape inserted in the sand mould to improve solidification of a region of the casting inaccessible to a riser thereby promoting directional solidification. A chill will produce local chilling and equalize the rate of solidification throughout the casting.

A chill may be classified as internal chill or external chill depending on its location in the mould. Chills placed inside the mould cavity are called internal chills. When the cavity is filled with molten metal, the chill will melt and become part of the casting. Thus internal chills are made from the same material as the cast part. On the other hand, external chills having high thermal conductivity are placed on the edge of the mould cavity thereby forming a part of the wall of the mould cavity. External chills are used to increase the feeding distance of a riser or reduce the number of risers.

(d) Use of Blind riser:

A conventional riser is open to atmosphere, whereas a blind riser is completely enclosed in the sand mould. As a result, the molten metal in the blind riser cools slowly and stay liquid longer thereby promoting directional solidification. Refer figure 3.17.

(e) Use of exothermic riser compounds:

Exothermic riser compounds are loose materials, essentially mixture of a metal oxide (Fe, Mn, Co, Ni, Cu, etc.) and aluminum, sprinkled on the top of riser in place of insulating powder. Their function is to prevent heat loss from the top of riser and also add some heat to the molten metal in the riser thereby allowing the metal to stay hotter necessary for achieving directional solidification.

3.5 DEGASIFICATION IN LIQUID METALS

As known, gases are much more soluble in liquid metal than in solid metal. As the liquid metal is poured into the mould and solidifies, it absorbs gases from various sources. These gases dissolve in molten metal as elements (H, C, O, etc.) and not as molecules (H₂, CO₂, etc.). On solidification, the elements may recombine to form molecular gases, and in doing so, form gas holes like blow holes, pin holes, etc., resulting in casting defects. Since it is not possible to completely prevent the absorption of gases in the melt, it is required to remove the dissolved gases, and the process adopted is known as degasification. Vacuum melting is used nowadays for preventing the dissolution of gases in metals.

3.5.1 Sources of Gases in Liquid Metals & Its Prevention

Gases are absorbed in molten metal from various sources as listed below:

1) Furnace atmosphere:

The atmosphere inside the furnace may contain water vapour, CO, CO₂, and SO₂ as products of combustion of fuel, in addition to the normal atmospheric gases such as nitrogen and oxygen. The amount of gas absorption depends on the conditions and the type of melting furnace. Maintaining clean and dry atmosphere inside the furnace and furnace walls helps in reducing gas absorption.

2) Furnace charge:

Wet or oily materials or contaminated scrap, charged into the furnace contribute to gas absorption. Alloying additions containing hydrogen resulting from the reducing conditions employed in smelting fluxes, and slag making additions are other sources. Use of dry and clean charge helps in reducing gas absorption.

3) Ladles:

Incompletely dried linings and surface of spouts, tundishes, and ladles, when brought in contact with the molten metal may help gas absorption through dissociation of steam at the contact surface. Use of clean, dry and preheated tools helps in reducing gas absorption.

4) Furnace to ladle or Ladle to mould:

Molten metal may absorb gases while it is transferred through air from ladle to mould, or during tapping from furnace to ladle. The gas absorption can be minimized by providing a protective atmosphere to the molten metal by means of slag, inert gas, exothermic compounds, etc. Further, pouring metal at temperatures as low as practically possible, and maintaining metal handling conditions like skimming, stirring, and re-ladling helps in reducing gas absorption.

5) In the mould:

Molten metal may absorb gases inside the mould, in case if the mould materials contain excess moisture or volatile hydrocarbons. Moulding materials free of volatile matter

and proper venting system in the mould helps in reducing gas absorption.

3.6 DEGASIFICATION METHODS

Following are the different methods of degassing:

- 1) Flushing
- 2) Vacuum degassing
 - Static bath treatment
 - Induction degassing
 - Stream droplet degassing
 - Fractional degassing

3.6.1 Flushing

Flushing or Gas scavenging with an inert gas* is one of the most effective methods of extracting dissolved gases from the molten metal. Inert gases such as chlorine, nitrogen, helium or argon are used in practice for degassing non ferrous metals, while carbon monoxide is used for ferrous metals and Ni based alloys. Figure 3.2 illustrates the principle of flushing with inert gas.

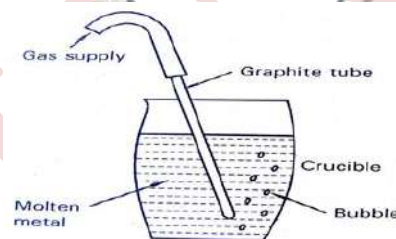

Figure 3.2 Flushing

In this method, the inert gas is simply piped from storage tanks through graphite tubes directly into the liquid metal. The piping of inert gas creates bubbles, which move upwards and any dissolved gas in the liquid melt migrates readily to the bubble where it collects and is flushed from the melt and to the atmosphere. The rate of degassing depends on the rate at which the gas diffuses in to the gas bubbles.

Note: For ferrous metals and Ni based alloys, nitrogen cannot be used as inert gas. They form nitrides that affect the grain size.

** An inert gas, also called as noble gas is a gas which does not undergo any chemical reactions when allowed to react with many substances. Purified nitrogen and argon gases are widely used as inert gases due to their availability and low cost. Inert gases are generally used in those applications in order to avoid unwanted chemical reactions especially oxidation and hydrolysis reactions with the oxygen and*

3.6.2 Vacuum Degassing

As the name suggests, vacuum degassing is a technique of removing dissolved gas from the liquid melt by lowering the pressure inside the vessel containing the liquid melt, in the presence of vacuum. It is particularly used in steel foundries for degassing hydrogen and oxygen from liquid steel. Steels refined in vacuum are characterized by homogeneous

structure, low content of non-metallic inclusions and low gas porosity.

Vacuum degassing is typically performed in a specially designed chamber or vessel known as vacuum degasser. There are a number of variants followed in the vacuum degassing process, however working on the same principle by exposing the molten metal to a low-pressure environment. The reduced pressure inside the vessel or chamber causes the dissolved gas to become less soluble and separate from the liquid melt. When the vacuum degassing process is complete, the gas is removed from the vessel, and the pressure is returned to normal. It must be noted that the effectiveness of any vacuum degassing operation depends upon the surface area of liquid melt that is exposed to low pressure. Hydrogen removal is a diffusion and partial pressure phenomenon, while Oxygen removal is a function of chemical reaction of oxygen with carbon and the partial pressure of carbon monoxide. The different variants of vacuum degassing with respect to hydrogen gas removal are discussed as follows:

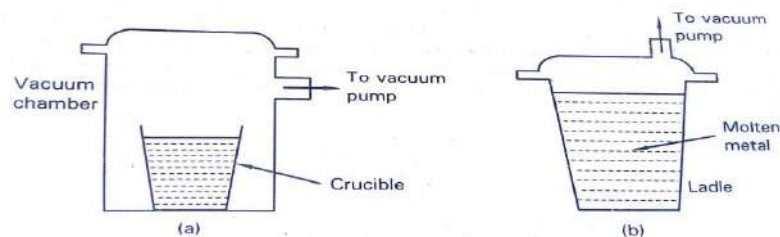

Figure 3.3 Static bath degassing technique

1) Static bath degassing: Static bath technique is the simplest form of degassing technique, wherein the ladle tapped with the molten metal is placed within a chamber, sealed and evacuated as shown in figure 3.3(a). The process although time consuming and requiring additional equipments may be simplified by sealing the tapped ladle itself with a cover as shown in figure 3.3(b). The space above the molten metal in the ladle forms the vacuum chamber. The reduced pressure inside the chamber causes the dissolved gas to become less soluble and separate from the liquid melt. Once the degassing process is completed, the pouring of metal is carried out. This system gives the advantage of a small pump down volume, reducing the vacuum pump capacity requirement. However, since the system does not utilize any circulation of the melt other than that provided by the natural convection, degassing proceeds at a slower rate.

2) Induction degassing:

Induction degassing technique overcomes the disadvantages of static bath technique. The system as shown in figure 3.4 consists of a crucible surrounded by induction heating coil, the entire assembly located within a chamber that can be sealed and rapidly evacuated. Molten metal is transferred from the melting unit into the crucible, wherein the current flowing through the coils create a magnetic field that induces eddy currents and circular electric currents producing a stirring action within the molten metal. The bath agitation which takes place at normal frequency is just sufficient for hydrogen gas removal from the melt to take place. The effect of removing dissolved gas is enhanced to a greater extent in the presence of vacuum atmosphere.

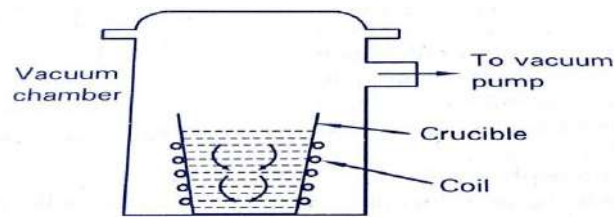

Figure 3.4 Induction degassing

Vacuum induction process is more efficient, except cost of the furnace being a major drawback. However, foundries operating with induction furnaces have the advantage, since all the operations like melting metal under vacuum, refining, degassing, heating, alloying, etc., are done in one single unit (melting furnace). The process is relatively flexible, featuring the independent control of time, temperature, pressure, and mass transport through melt stirring.

3) Stream droplet degassing:

In stream degassing technique, the molten metal from the ladle is poured down in to another preheated ladle placed in an evacuated chamber as shown in figure 3.5.

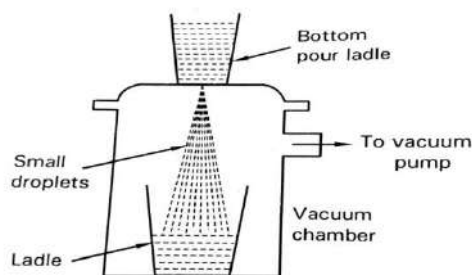

Figure 3.5 Stream droplet degassing technique

Bottom pouring of molten metal is desirable as it creates a stream of flow in to the vacuum chamber. The sudden exposure of liquid stream in the vacuum chamber leads to very rapid degassing due to the increased surface area created by break-up of stream into droplets. The process helps the hydrogen gas dissolved in steel to be evacuated by a vacuum pump. The major amount of degassing occurs during the fall of liquid stream, and as such the height of the pouring stream forms an important design parameter in the process.

4) Fractional Degassing:

In fractional degassing technique, the molten metal to be tapped in the ladle is progressively degassed by treatment of fractions of the metal in a separate pump metal vacuum vessel as shown in figure 3.4. The system makes use of two tubes connected at the bottom of the vacuum chamber with one of the tubes Argon - connected to a pipe supplying argon gas through its refractory lining. Both the tubes are immersed into the ladle containing molten metal. With such an arrangement, the liquid metal flows up in to the vacuum chamber under the influence of inert gas bubbles bled into the base of the tube.

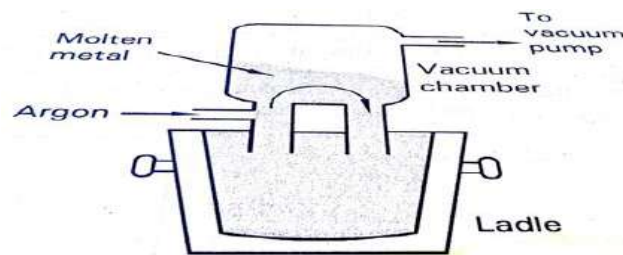

Figure 3.6 Fractional degassing

The Figure 3.6 Fractional degassing level of the molten metal in the vacuum chamber is determined by the atmospheric pressure. Through the second tube in the vacuum chamber, the molten metal flows down back to the ladle producing continuous circulation of the melt and resulting in the removal of gases.

Fettling and cleaning is carried out following the shakeout (removal of casting from sand mould) and knockout (removal of sand core from casting) operations. Fettling includes the following steps:

a) Removal of sand and other impurities: The rough casting removed from the mould consists of adhering moulding sand, core sand, oxides and scale which has to be cleaned. This is achieved manually, mechanically or by chemical means. Wire brush, files and other tools are used in manual operations, while air blasting, hydro-blasting, tumbling etc., are a few equipments used in mechanical operations. Chemical cleaning methods utilize baths of molten caustic soda containing additional reagents to react with and break the surface oxide layer. This loosens adhering sand also.

b) Removal of excess metal:

This step includes removing excess metal such as fins*, blisters, stumps of gates and risers, and other unwanted projections from the castings. This is achieved by chipping, sawing, flame cutting, grinding and other operations.

c) Finishing of castings:

Finishing is carried out to smoothen parts of the casting where gates and risers were attached, and also improve the surface finish and appearance of the casting. Different finishing operations like Grinding, Polishing, Buffing, etc., are used for the purpose.

3.7 FETTLING / CLEANING OF CASTINGS

Fettling and cleaning is carried out following the *shakeout* (removal of casting from sand mould) and *knockout* (removal of sand core from casting) operations. Fettling includes the following steps:

a) Removal of sand and other impurities

The rough casting removed from the mould consists of adhering moulding sand, core sand, oxides and scale which has to be cleaned. This is achieved manually, mechanically or by chemical means. Wire brush, files and other tools are used in manual operations, while air blasting, hydro-blasting, tumbling etc., are a few equipments used in mechanical operations. Chemical cleaning methods utilize baths of molten caustic soda containing additional reagents to react with and break the surface oxide layer. This loosens adhering sand also.

b) Removal of excess metal

This step includes removing excess metal such as fins*, blisters, stumps of gates and risers, and other unwanted projections from the castings. This is achieved by chipping, sawing, flame cutting, grinding and other operations.

c) Finishing of castings

Finishing is carried out to smoothen parts of the casting where gates and risers were attached, and also improve the surface finish and appearance of the casting. Different finishing operations like Grinding, Polishing, Buffing, etc., are used for the purpose.

3.8 CASTING DEFECTS

Casting process involves a number of variables, and a loss of control in any of these variables can cause defects' under certain circumstances. Some of the common casting defects, their features and remedies to prevent such defects are discussed below.

(a) Shrinkage defect

Shrinkage is a void on the surface of the castings resulting from contraction or shrinkage of metal during solidification. Refer figure 3.7. Although a riser is used to overcome the shrinkage effect, in some cases it fails to feed the molten metal efficiently to the casting as it solidifies.

* *Fin* - Metal on a casting caused by an imperfect joint in the mould or die.

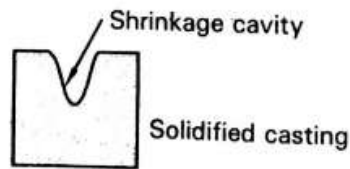

Figure 3.7 Shrinkage defect

Remedies

- Use large sprue and riser to promote directional solidification.
- Locate risers and gating systems in correct positions.
- Gates to be cut as wide as possible.

(b) Porosity defect (Blow hole and Pin hole)

Molten metal absorb gases from various sources such as fluxes, moisture in sand, binders, additives and normal atmospheric gases like oxygen and nitrogen. If these gases are not allowed to escape, they get entrapped in the mould cavity forming small balloon shaped voids or cavities leading to porosity defect in castings. Two types of gas related defects occur in castings. They are: blow hole and pin hole

defect.

Blow holes occur below the surface of the castings and are not visible from the outside surface. Refer figure 3.8 (a). On the other hand, pin holes are small gas cavities, many in number at or slightly below the surface of the casting. Refer figure 3.8 (b).

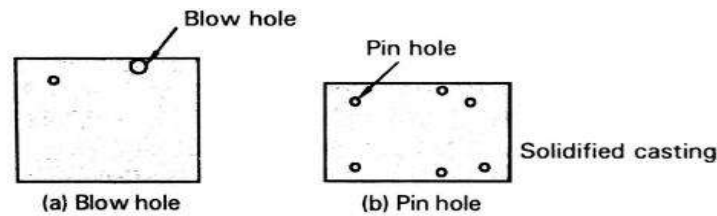

Figure 3.8 Porosity defect

Remedies

- Avoid excess ramming of mould.
- Provide proper vent holes.
- Avoid use of excess carbonaceous or other organic material in the sand/core binders, because these materials react with the molten metal producing large amount of gases.

(c) Misrun

Misrun occur when the mould cavity is not completely filled with molten metal. In other words, it is a defect wherein a casting solidifies before the molten metal completely fills the cavity. Refer figure 3.9.

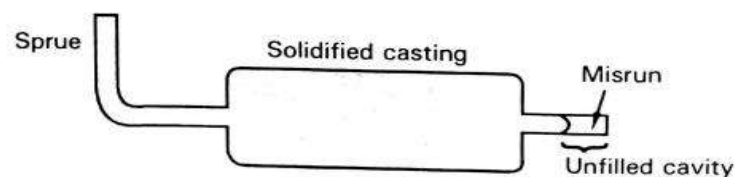

Figure 3.9 Misrun

Remedies

- Fluidity of metal should be maintained suitably.
- Pouring rate and time should be controlled.
- Thin sections should be suitable designed.

(d) Penetration

When fluidity of liquid metal is high, it may penetrate into the sand mould/core (into the voids between the sand particles). A fused aggregate of metal and sand appears on the surface of the casting leading to defect. Refer figure 3.10.

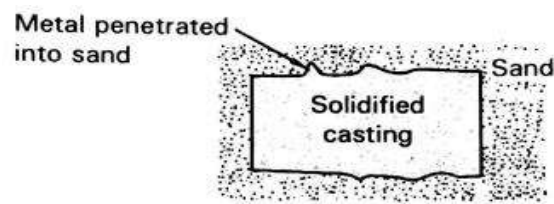

Figure 3.10 Penetration

Remedies

- Sand should be properly rammed.
- Moulding sand/core sand should not be too coarse to promote metal penetration.
- Control proper metal temperature. Fluidity of molten metal should be maintained suitably.

(t) Mould shift

It is a *step* produced in the cast product along the parting line due to the sidewise relative displacement of cope and drag box. Refer figure 3.11.

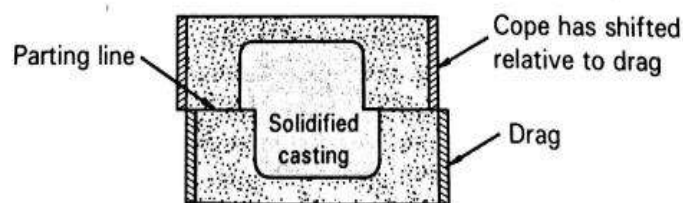

Figure 3.11 Mould shift

Remedies

- Proper alignment of cope and drag box.
- Proper handling of assembled cope and drag box during operations.

(g) Cold shut

Two portions of metal flow together, but lack of fusion due to premature freezing results in a defect known as cold shut. Refer figure 3.12.

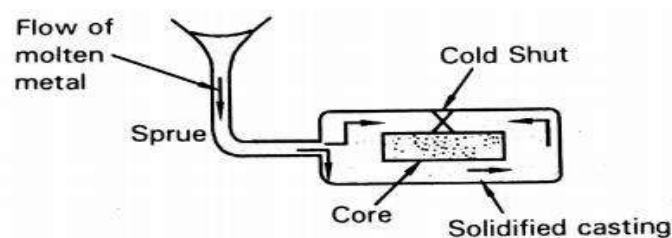

Figure 3.12 Cold shut

Remedies

- Place gates and risers at proper locations.

- Metal fluidity should be high.

(h) Hot tears

A hot tear is an internal or external ragged discontinuity formed in the casting due to the pulling action of the metal just after it has solidified. Refer figure 3.13.

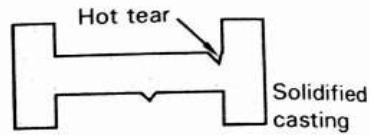

Figure 3.13 Hot tear

Remedies

- Provide adequate fillets at sharp corners while designing the component.
- Proper metallurgical and pouring temperature to be maintained.
- Place gates and risers at suitable locations.

3.9 ADVANTAGES & LIMITATIONS OF CASTING PROCESS**Advantages**

- a) Large hollow and intricate shapes can be easily cast.
- b) Quick process, and hence suitable for mass production.
- c) No limit to size and shape. Parts ranging from few millimeters to meters and few grams to tons can be cast efficiently and economically.
- d) Better dimensional tolerances and surface finish can be obtained by good casting practice.
- e) Castings exhibit uniform properties in all the directions—longitudinal, lateral & diagonal.

Limitations

- a) Presence of defects in cast parts is a major disadvantage.
- b) Casting process is not economical for small number of parts.
- c) Properties of cast materials are generally inferior when compared to those made by machining or forging process.
- d) Process parameters are many, right from pattern making to pouring and solidification of molten metal. Monitoring these parameters to produce a good casting is a tough task.

3.10 INTRODUCTION TO NON FERROUS FOUNDRY PRACTICE

As known, ferrous metals contain iron as its chief constituent element, while non-ferrous metals do not contain iron. Ferrous metals are preferred owing to their high strength and durability, while non ferrous metals are preferred due to their light weight and corrosion resistance. Although the technique of casting remains the same for both types of metals, the foundry practice varies to a larger extent and hence there is a need to study the various aspects related to non ferrous foundry practice. However from the syllabus point of view, the discussions presented in this chapter is confined to Aluminum, alloy — the most widely used non ferrous metal in casting technology.

3.11 ADVANTAGES & LIMITATIONS OF ALUMINUM CASTINGS**Advantages**

- 1) Of all the non ferrous castings, aluminum castings exhibit high-strength-to-weight ratio.
- 2) Aluminum casting alloys display excellent fluidity characteristics for casting thin sections and fine

details.

- 3) Aluminum casting alloys melt at relatively low temperatures thereby reducing the problems related to melting, pouring, and essential furnace requirements.
- 4) Aluminum castings can be produced almost by every known process thereby offering a broad range of volume, productivity, quality, mechanization and specialized capabilities.
- 5) Metallurgically or mechanically bonded bimetal parts can be routinely cast.
- 6) Aluminum castings require low capital requirements.
- 7) Owing to its high-strength-to-weight ratio, and corrosion resistance, aluminum castings are preferred in aerospace and automotive industries.

Further, due to its non-toxicity, aluminum castings are used for cooking utensils, food handling and medical equipments;

Limitations

- 1) Aluminum castings are more expensive than ferrous based castings.
- 2) Aluminum castings exhibit poor resistance to abrasion and wear.
- 3) Variation in alloying elements affects properties to greater extent.

For example: - Al—Cu alloy castings exhibit greater strength and hardness, while decreased castability; Al—Si alloy castings exhibit outstanding castability and wear resistance, however prone for gas porosity. Optimum properties can be achieved with proper inclusion of alloying elements.

3.12 MELTING OF ALUMINUM ALLOYS

Aluminum alloys can be melted in direct or indirect fuel fired furnace or in electrically heated furnace like crucible furnace, induction furnace etc. The present section describes the details of Lift-out type crucible furnace.

Lift-out type Crucible furnace

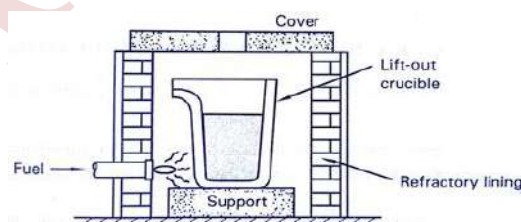

Figure 3.14 Lift-out crucible furnace

The lift-out type of crucible furnace is one of the oldest and simplest type of furnace used for melting aluminum alloys (also other non ferrous alloys) in small volumes. The furnace as illustrated in its simplest form in figure 3.14 consists of a crucible made from a refractory material, usually a clay-graphite mixture, or of a high temperature steel alloy. The crucible itself acts as a ladle. The charge placed inside the crucible is heated through the walls of the crucible by means of heat sources like oil, gas, or electricity. After the melt has reached the desired state, the crucible is lifted out of the

furnace with tongs and the molten metal is directly poured into the mould.

3.13 HARDENERS USED, IN ALUMINUM CASTINGS

The mechanical and physical properties of Aluminum castings are enhanced with the use of alloying elements. However, aluminum is a low melting point (660°C) metal, and most of the alloying elements having favourable properties have comparatively greater melting points. In such a case, the alloying elements do not mix readily with the low melting point aluminum metal, and hence master alloys or hardeners are often used. Hardeners are available in a number of alloys including Ca, Co, Cu, Cr, Mn, Mg, Ni, Si, Ti, V, Zr, Zr- V, and more.

For example, chromium has a melting point of about 1875°C . is used as a hardener with the aluminum melt in order to impart strength, hardness, and oxidation resistance; the aluminum-chromium alloy combination is called as master alloy and chromium as hardener. Initially chromium is allowed to reach the molten state, and in this condition, solid aluminum is added and is quickly dissolved in the liquid chromium.

Aluminum-based master alloys which contain the hardener elements in high concentrations, now provide a convenient and economical way to add them to molten aluminum to achieve the desired final properties. These master alloys readily go into solution at lower liquid aluminum temperatures, thus minimizing dross formation and solubility of hydrogen. The amount of aluminum and hardeners used is calculated during the course of melting so as to bring the final aluminum casting to the desired specification.

3.14 DROSSING

Dross is a mass of solid impurities floating on the surface of low melting point metals such as aluminum, tin, lead, zinc, etc., as a result of oxidation of the molten metal. With reference to aluminum castings, the term Drossing is specially used to denote the formation of aluminum oxide and other oxides * that collect on the surface of the molten aluminum metal when coming in contact with air.

Dross can be minimized when melting is made faster, or protecting the molten metal coming in contact with the products of combustion or atmospheric air. However, even with its formation, the dross product need not be considered a waste material, instead can be recycled either mechanically or chemically and reused.

Oxide Separation and Removal

Drossing fluxes are designed for chemical means (Fluxing) to promote separation of the aluminum oxide (Al_2O_3) dross layer that forms on the surface of the melt from the molten metal. Either solid or chemically active gaseous fluxes containing chlorine, fluorine, chlorides, and/or fluorides are used for the purpose. The drossing flux reacts with Al_2O_3 in the dross layer by de-wetting of the oxide-melt interface to provide effective separation of oxides and other included matter thereby helping in recovering aluminum metal.

In the mechanical process, the hot dross is placed into a press that squeezes and separates into aluminum metal rich particles and aluminum oxide rich particles based on density. The metal rich particles are then melted in a furnace to remove the remaining oxide particles.

3.15 GAS ABSORPTION IN ALUMINUM CASTINGS

Hydrogen is the only gas that is appreciably soluble in aluminum and its alloys. Its solubility varies directly with temperature and the square root of pressure. During the cooling and solidification of molten aluminum, dissolved hydrogen in excess of the extremely low solid solubility may precipitate in molecular form, resulting in the formation of primary and/or secondary voids like pin holes or gas porosity.

Fluxing and Flushing of aluminum melts are practiced mainly for two purposes as listed below:

- 1) To separate molten aluminum metal from the aluminum oxide dross layer
- 2) To remove dissolved hydrogen and entrapped dross from the melt.

In the flushing method as also discussed in section 3.6.1, inert gases like chlorine, nitrogen, helium or argon gas is simply piped from storage tanks through graphite tubes directly into the liquid metal. The piping of inert gas creates bubbles, which move upwards and the hydrogen gas dissolved in aluminum melt migrates readily to the bubble where it collects and is flushed from the melt and to the atmosphere. Dross separation by fluxing is due to the mechanical action of the inert gas bubbles carrying oxides to the surface.

Fluxing means adding suitable agents in order to achieve the following:

- 1) To react with the dross so that it can float up,
- 2) To prevent reaction of the melt of aluminum with atmosphere by acting as a barrier, and
- 3) To absorb impurities in the melt.

All aluminum alloys, in general, are melted under flux cover of halide salts. These fluxes contain salt mixtures that are liquid at normal aluminum melting temperatures.

Typical fluxes are:

- a) 47.5% sodium chloride, 47.5% potassium chloride, and 5% sodium aluminum fluoride, or
- b) 45% KCl, 45% NaCl and 10% NaF.

Other cover flux combinations include aluminum and zinc chlorides. Some manufacturers of cover flux recommend that the flux should be stirred in the melt to be effective, so that the dross can be easily separated from the metal.

** Most oxides are of aluminum, but alloying elements such as magnesium, iron, copper and titanium also can form their oxides.*

3.16 GRAIN REFINEMENT IN ALUMINUM ALLOYS

Grain size in an aluminum alloy refers to size of individual aluminum crystals in the solidified part. The size of these crystals is directly related to the number of grains or nuclei formed during the initial stages of solidification or during pouring of metal. The more the number of grains, the finer the grain size will be, thereon having the ability to promote improved casting soundness by minimizing shrinkage, hot cracking, and hydrogen porosity. Also, the mechanical properties are greatly enhanced with fine grain structure.

Grain size in aluminum alloys can be refined by the following three methods:

1) Thermal method:

Thermal method involves rapid cooling (chilling) of liquid metal and subsequently variation of process variables. A fine equiaxed grain structure arises when casting is carried out in cold molds and under low superheating conditions.

2) Chemical method:

Chemical methods involve the addition of some elements called grain refiners that promote nucleation and hindering crystal growth. Inoculation is a typical example of this method and is the most common practice by adding Al-Ti-C or Al-Ti-B ternary master alloys to the liquid melt before casting. These particles act as a-Al grains, resulting in a uniformly fine equiaxed grain structure in aluminum castings.

3) Mechanical method: Mechanical refining method involves stirring or agitation of the melt during solidification by using ultrasonic, electromagnetic & mechanical stirring methods. Since most of the techniques require long processing time and special devices, this method is usually applied to semisolid metal processing.

3.17 POURING TEMPERATURE

Pouring temperature refers to the temperature of the molten metal before it is poured into the mold. The pouring temperature has to be higher than the solidification temperature of the metal in order to allow the free flow of molten metal in to all regions of the mould cavity well before solidification is completed. However, it must be noted that the temperature difference must not be too high as heat from the mould cavity has to be quickly removed in order to speed up the solidification process. The difference between the solidification temperature and the pouring temperature of the metal is designated by the term superheat, which is the most important parameter to be considered in melting and pouring operations. For example, aluminum alloy has melting temperature of 660°C with its corresponding pouring temperature range between 700°C — 750°C. For better end results, it is desired to pour the metal at the lowest possible pouring temperature.

The pouring temperature is estimated by taking into consideration, the various factors like melting and freezing temperature of metal, heat loss due to the transfer of metal through ladles, and mould, the shrinkage behaviour of the pouring metal, and thinnest sections of cast part. In order to protect the molten metal from losing its heat, it is always covered by exothermic compounds, which are mixtures of metal oxides and aluminum.

3.18 STIR CASTING

Foundry practice has led to various technological advances with respect to materials and processes from which metals can be efficiently and economically cast. Stir casting is one of the advanced liquid cast metal technology in producing aluminum based metal matrix composites by employing stirring principle of liquid metal. The concept and benefits of stirring or agitation of molten metal goes back to the foundry age where stirring of liquid metal was accomplished by lance gas injection in to the liquid metal. Stirring action within the molten metal helps in easy mixing and melting of alloys as well as homogenizing of temperature throughout the furnace. Although

successful to a quite extent, the process suffered from limited effectiveness as well as increased dross formation.

However, the concept gave way to new technologies and today advanced subsurface stirring technologies like pneumatic jet stirring, electromagnetic approaches and rotary devices have been employed for stirring purpose.

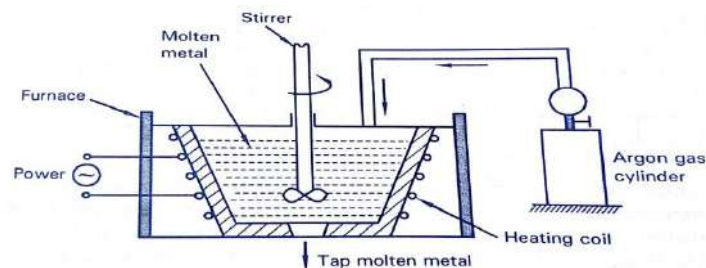

Figure 3.15 Stir casting set-up

Operation

The schematic representation of stir casting process is illustrated in its simplest form in figure 3.15. The arrangement consists of a furnace inside which a graphite or cast iron crucible surrounded by a coil of copper wire is placed. The crucible holds the charge of metal to be melted. A powerful alternating current flows through the coil of the wire creating a rapidly reversing magnetic field that penetrates the metal. The magnetic field induces eddy current, and circular electric currents inside the metal by electromagnetic induction thereby producing stirring action within the molten metal.

Meanwhile, the reinforcements or alloying elements are added to the molten metal and then stirred continuously by means of a stirrer for a short duration to create a vortex that forces the slightly lighter particles into the melt. The molten metal is then transferred in to a preheated ladle and then poured in to the mould of the desired shape. Since aluminum reacts rapidly with the surrounding oxygen, an inert gas like argon gas is used as the carrier gas to assist injection of the alloying elements (reinforcements) and pouring metal in a clean form.

Note: An interesting development in stir casting is a two-step mixing process. In this process, the aluminum matrix material is heated to above its liquids temperature so that the metal is totally melted. The melt is then cooled down to a temperature between the liquids and solidus points and kept in a semi-solid state. At this stage, the preheated reinforcement or alloying particles are added and mixed. The slurry is again heated to a fully liquid state and mixed thoroughly. This two-step mixing process has been used in the fabrication of aluminum

Advantages of stir casting

- Stirring action within the molten metal helps in easy mixing and melting of alloys as well as homogenizing of temperature throughout the furnace leading to sound castings.
- Stirring action helps in removal of hydrogen gas.
- Eliminates porosity
- Better dimensional control and tolerances in castings
- Clean and sound castings can be obtained.

Disadvantages

- Equipment is costlier.
- Excessive stirring can increase gas pick up, furnace lining wear, and oxidation of alloys.
- Stirring speed and time has to be monitored appropriately, as it has a direct influence on the

hardness of the cast metal.

- Monitoring an inert gas atmosphere is an additional requirement.



MODULE4**WELDING PROCESSES****Welding definition**

Welding is process of joining two materials (similar or dissimilar) by the application of heat with or without the application of pressure and addition of filler material. All metals and alloys can be welded. The materials to be joined are held in contact together and the required energy is applied mainly in the form of heat. This heat fuses the material and on cooling the joint solidifies. The joint formed is called welded joint. Heat is the main source of energy, which can be obtained by electricity, gas or chemical reaction or friction. Welding is a fabrication process.

Advantages:

- Any metal/alloy can be welded
- Any shape of component can be generated
- Strength of the joint will be the same as that of the base metal.

Disadvantages / Limitations:

- Harmful radiation and fumes may be generated during the process
- Residual stresses may be setup in the welded joint
- Skilled operator may be required
- Structure of the weld portion will differ from parent metal.

Application:

Fabrication of aircraft and automobile components, bridges, building structures, ships, pressure vessel, pipes, etc.

Classification of welding

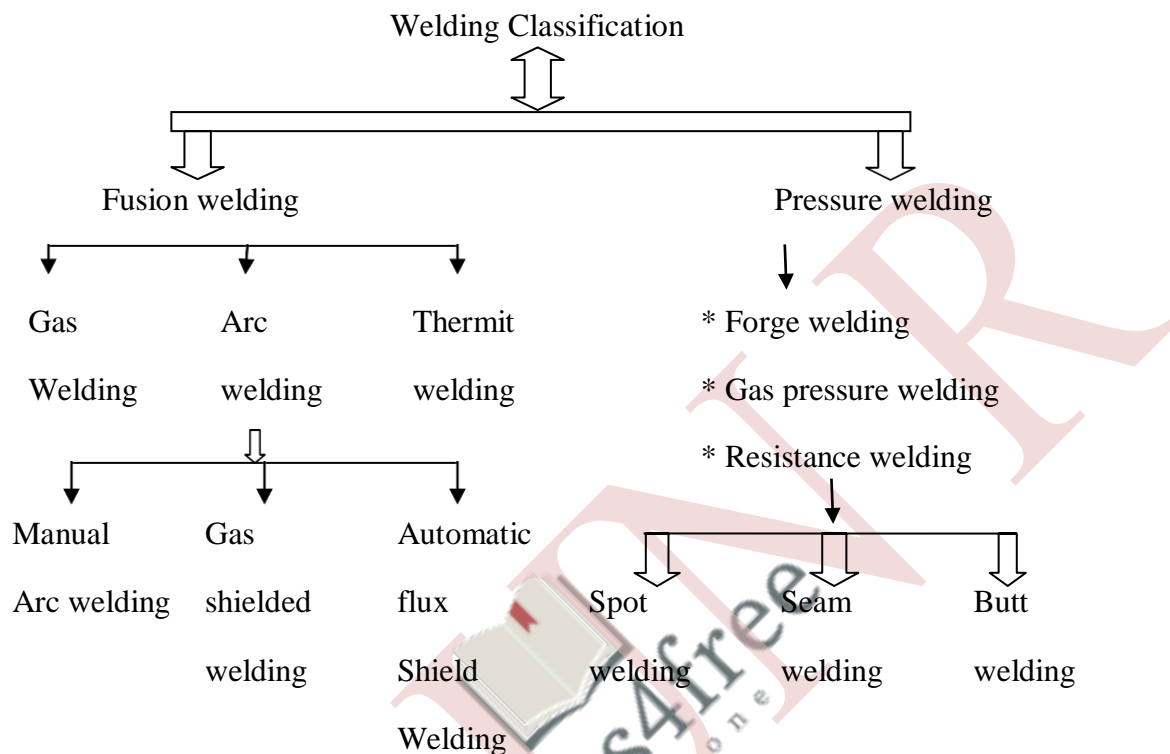

The detailed classification of welding processes are:

Gas welding

- * Air acetylene welding
- * Oxy hydrogen welding
- * Oxy acetylene welding
- * Pressure gas welding

Arc Welding

- * Carbon arc welding
- * Shielded metal arc welding
- * Flux cored arc welding
- * Submerged arc welding
- * Tungsten inert gas welding
- * Metal inert gas welding
- * Plasma arc welding
- * Electro slag welding
- * Stud arc welding

Resistance Welding

- * Spot welding
- * Projection welding
- * Flash welding
- * High frequency resistance welding

METAL CASTING AND WELDING

* Resistance butt welding

Solid State welding

* Cold welding

* Explosive welding

* Friction welding

* Roll welding

* Diffusion welding

* Forge welding

* Hot pressure welding

* Ultrasonic welding

Thermo chemical welding

* Thermit welding

* Atomic welding

Radiant Energy welding

* Electronic beam welding

* Laser beam welding

Using consumables electrodes

* Metal arc welding

* Gas shielded metal arc welding

* Submerged arc welding

* Plasma welding

Commonly welded metals

Metals that are welded on a regular basis are classified under two categories:

Ferrous Metals ↔ **Non Ferrous Metals**

Ex. Wrought iron

Ex. Aluminium alloys

Carbon steel

Copper alloys

Cast steel

Stainless steel

ARC WELDING

It is a fusion welding process. Here an electric arc is used as the heat source. An electric arc is a continuous stream of electron flowing between two electrodes into a medium. This gives rise to intense heat generation. This is used to melt the surface and deposit the metal from the electrode resulting in a joint on cooling.

Principle:

The source of heat for arc welding process is an '*electric arc*' generated between two

METAL CASTING AND WELDING

electrically conducting materials. One of the workpiece material called electrode is connected to one pole of the electric circuit, while the other workpiece which forms the second conducting material is connected to the other pole of the circuit.

When an arc is struck between a metal electrode and the work, the arc heats the metal and forms a pool of liquid. The electrode material can be either non-consumable or consumable. The non-consumable electrode made of tungsten, graphite, etc., serve only strike the arc, whereas, the consumable electrode which is made of the same material as that of workpiece strike the arc and gets consumed. The electrode gets consumed as and when the metal is deposited. The liquid pool of metal mix the work and becomes a part of it. On cooling, solid metal of homogeneous bond results. A joint is formed. The distance between the tip of the electrode and the work through which arc is formed is termed as '*arc length*'.

Metal Arc Welding (MAW)

- It is also referred as consumable electrode arc welding.
- Arc is struck between the work and electrode which melts and furnishes the required feed metal.
- Both the rod and the work melt.
- Both AC and DC supply can be used.
- Arc supplies the required heat.
- The temperature and the heat input can be increased or decreased by increasing or decreasing the arc current.
- High arc current and low arc length produces high intense heat.
- The metallic rod is normally coated with a flux.
- The flux coating melts and produces slag which covers the molten metal at the joint.
- The slag formed will also give the arc stability.
- An arc length of 0.6 to 0.8 times the electrode diameter yields high quality weld.

Flux Shielded Metal Arc Welding (FSMAW)

The welding is carried out manually, and then it is referred to as Manual Metal Arc Welding (MMAW).

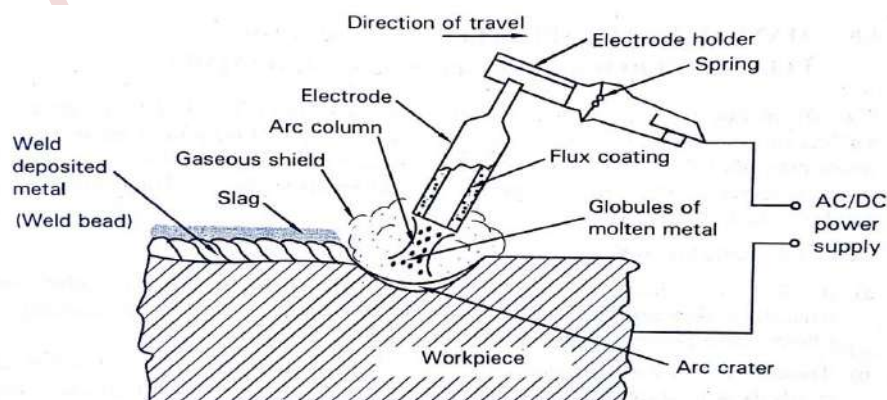

Figure 4.2 Flux shielded metal arc welding

METAL CASTING AND WELDING

- The surface of the work is cleaned to remove dirt to obtain a sound weld.
- The work pieces are held in position.
- Welding leads are connected to the power source and the work piece.
- Power is switched on and a suitable current is allowed to pass.
- Electrode is gripped by means of a holder and strikes the arc, by moving the electrode near to the workpiece.
- The arc length is adjusted, such that continues stable arc and supply of molten metal.
- During welding, slag is used as a protection to the molten metal.
- Flux acts as a shield to the weld portion.
- This is referred to as Flux Shielded Metal Arc Welding (FSMAW).

Tungsten inert gas welding (TIG)

An arc is struck between the non-consumable tungsten electrode and the workpiece in the presence of an inert gas such as helium or argon, which is passed near the arc thereby creates a shield. This is referred to as Tungsten Inert Gas Welding (TIG). A filler rod is used to supply molten metal to the joint. Fig. 4.3 shows the TIG welding. Pressure of the gas varies between 0.1 to 0.15 N/mm². Mainly DC supply is used.

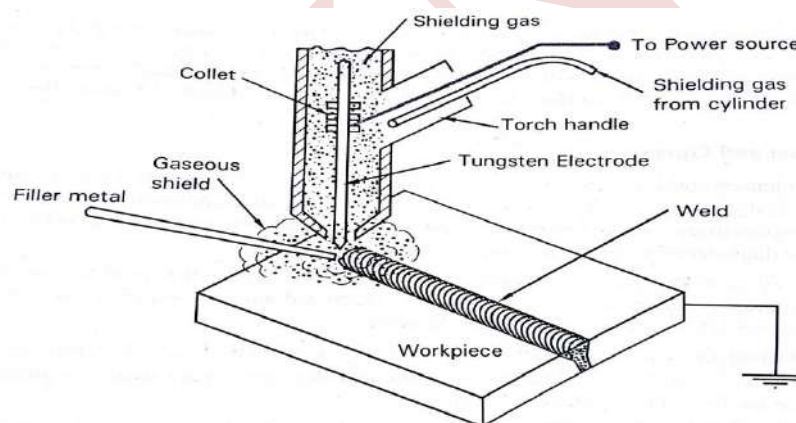

Figure 4.3 Tungsten Inert Gas (TIG) welding

Fig. 4.3 Tungsten inert gas welding (TIG)

Advantages:

- Suitable for thin metals
- Clear visibility of the arc provides the operator to have greater control over the weld.
- Strong and high quality of joints are obtained.
- No flux is used, no slag formation, results in clean weld joint.

Disadvantages:

- TIG is most difficult process compared to all the other welding process.
- Skilled operator is required.
- Process is slower.
- Not suitable for thick metals.

Application:

TIG welding is most commonly used to weld stainless steel and non-ferrous materials such as aluminium and magnesium. Aerospace industry is one of the primary user, refrigerators, air conditioners and chemical plants are other users.

Metal Inert Gas Welding (MIG)

Metal inert gas welding, in which the workpiece is joined by the heat obtained from an electric arc struck between a metal consumable electrode (uncoated) and the workpiece in the presence of an inert gas, which is a mixture of argon & carbon dioxide. The consumable metal electrode itself will supply the required metal. No filler is required. Fig. 4.4 shows the MIG welding.

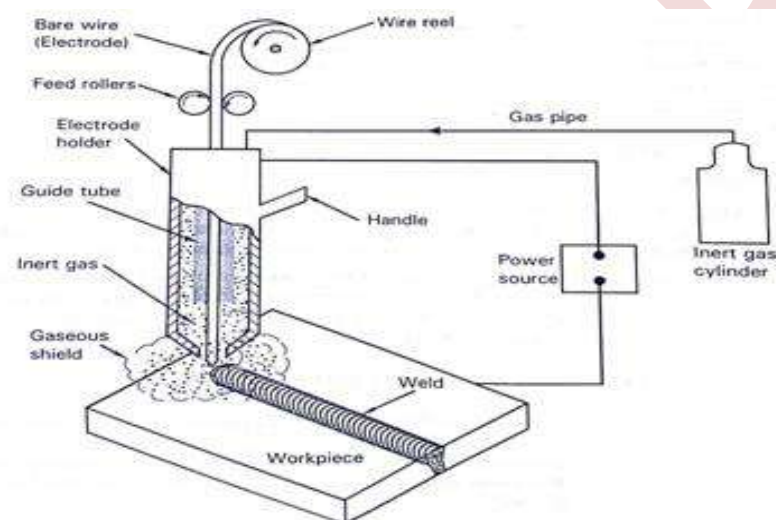

Figure 4.4 Metal Inert Gas (MIG) welding

Fig. 4.4. Metal Inert Gas Welding (MIG)

Advantages:

- MIG welding is fast and economical.
- Weld deposition rate is high due to continuous wire feed.
- No flux is used, no slag formation, clean weld is obtained.
- Process can be automated.

Disadvantages:

- Equipment is costlier.
- Dross & porosity are the most prevalent quality problem.

Application:

It is used extensively in sheet metal & automobile industry.

Submerge Arc Welding (SAW)

An arc is struck between a consumable electrode and the parent metal, buried under a granular flux such as TiO_2 , SiO_2 . Granular flux is allowed to drop through the hopper near the arc. Flux melts and forms a liquid. The rod supplies the molten metal for welding. Liquid flux covers the molten metal with an impermeable slag and protects the weld until it cools. Fig. 4.5 shows the SAW.

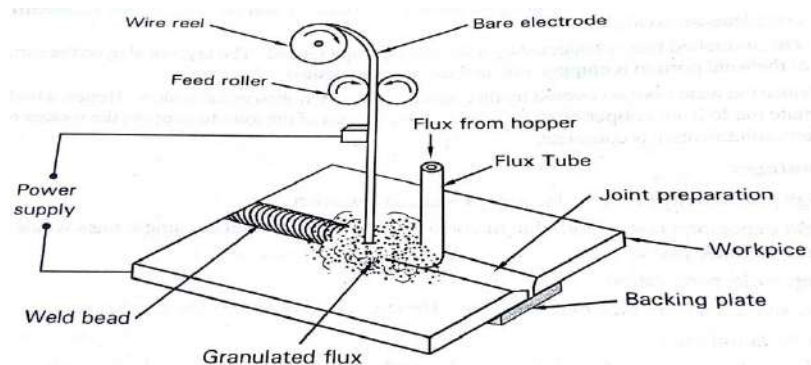

Figure 4.5 Submerged arc welding

Fig. 4.5 Submerge Arc Welding (SAW)

Advantages:

- Weld deposition rate is high due to continuous wire feed.
- High productivity process due to high heat generation.
- Deep weld penetration.
- Can be automated.
- Less smoke, as the flux hides the arc.

Disadvantages:

- Use of powdered flux restricts the process to be carried only on a flat position.
- Need for extensive flux handling.
- Slow cooling rate may lead to hot cracking defects.

Applications:

Used especially for large products in the fabrication of pressure vessels, penstocks, boilers, etc.

Atomic Hydrogen Welding (AHW)

It is a welding process wherein fusion is produced by heating the job with an electric arc maintained between two tungsten electrodes in an atmosphere of hydrogen, which also acts as a shielding gas. Filler rod and pressure may or may not be applied depending upon the condition.

Principle:

- It possesses the features of both arc and flame welding processes.
- The job does not form a part of the electric circuit.
- Combined energy of the arc and a chemical reaction is utilized for welding.
- Electric arc is struck between two tungsten electrodes.
- This arc supplies energy for a chemical reaction.

Chemical reaction:

The molecular hydrogen passes through the electric arc and it dissolves into atomic hydrogen by absorbing the energy supplied by the electric arc.

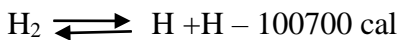

The atomic hydrogen thus formed is unstable and has a tendency to revert back to molecular state. This recombination takes place as the atomic hydrogen touches a relatively cold work piece to be welded. The recombination is an exothermic reaction which liberates large amount of heat (app., 3730°C). This heat combined with that of the arc is utilized for welding process. Because of very high heat conductivity of hydrogen at elevated temperatures, the heat is delivered to work piece at very fast rates.

Equipment

1. Welding torch with tungsten electrodes and cable.
2. Hydrogen gas supply.
3. AC power source (a transformer with an open circuit voltage of about 300 volts).

Fig. 4.6 shows the detail.

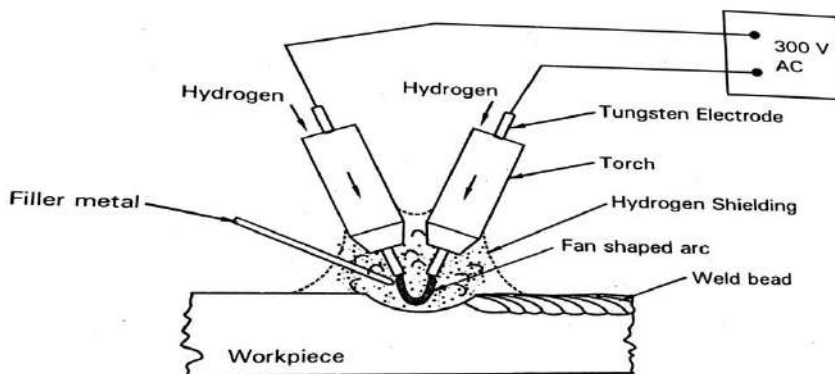

Figure 4.6 Atomic hydrogen welding

Operation:

- Hydrogen gas supply is made and current is switched on.
- The arc is struck by bringing the two tungsten electrodes in touch with each other momentarily and then separating them by a pre-determined distance (say 1.5 mm).
- Depending upon the thickness of the job to be welded a current value can be set.
- The atomic hydrogen welding arc is held over the job till a molten pool forms.
- The welding torch is carried along the surface to be welded with the arc edge touching the surface.
- Hydrogen creates a reducing atmosphere and avoids weld metal contamination.
- Depending upon job thickness filler metal may or may not be added.
- For welding a mild steel plate of 10mm thickness, about 60 amps of arc current is required.

METAL CASTING AND WELDING

Advantages:

- ✓ No flux or separate shielding gas is used; hydrogen itself acts a shielding gas and avoids metal oxidation.
- ✓ The job does not form a part of the electrical circuit.
- ✓ The arc remains between two tungsten electrodes and can be moved to other places easily without getting extinguished.
- ✓ Welding of thin materials is also possible which otherwise may not be successfully carried out by metallic arc welding.
- ✓ Due to high concentration of heat, welding can be carried out at fast rates and with less distortion of work piece.

Disadvantages:

- ✓ The process cannot be used for depositing large quantities of metals.
- ✓ Welding speed is less as compared to that of metallic arc or MIG welding.
- ✓ The process becomes uneconomical for certain applications because of higher operating cost as compared to that of other welding processes.

Application:

The process can be used for the welding of most of the metals and alloys like plain carbon steel, alloy steel, stainless steel, aluminium, copper, nickel and their alloys.

SPECIAL TYPE OF WELDING

RESISTANCE WELDING

Whenever a heavy electric current is passed through a material, the material will offer resistance to the flow of current. This results in local heating of the material. This principle is used to generate the required heat at the joint for welding. The quantity of heat generated in the material due to the current flow is given by Joules law : **$Q \propto I^2 R t$**

$$Q = 0.24 \times I^2 R t$$

Where,

- Q= Heat generated in calories
- 0.24= Constant of proportionality
- I^2 = Current in the Circuit in amperes
- R= Resistance in the circuit in Ohms
- t= Time of flow of current in seconds

- Heat generated is very rapid as very high currents of 300-10⁵ amps with a voltage upto 25 volts is used.
- A transformer is used for the purpose.
- AC source is used.
- The parts to be joined are heated to plastic state and high pressure is applied.

- This results in joint, after cooling.
- Current consumed depends on the area of contact and time.
- Pressure applied is approximately around 25-55 N/mm².
- No filler metal is required for the purpose.
- Copper electrode is used to carry the current to the joint.
- Resistance welding can be used for all metals except tin, lead & zinc, as they pose several problems.

Advantages of Resistance Welding

- No filler rod required
- Fast rate of welding is possible
- Semi skilled workers can be employed
- Both similar and dissimilar metals can be welded
- Very high reliability and reproducibility obtained in the welds
- Semi automatic equipments can be used

Disadvantages of resistance welding

- Initial cost of equipments is high
- Needs good control and maintenance of equipments
- Higher thickness of metal cannot be welded
- Process is simple and the operation is very rapid. Used for mass production.

Application of resistance welding

- Used for joining sheets, bars, rods and tubes.
- Used for welding aircraft automobile parts.
- Used for general engineering fabrication purposes like grills, containers, tanks, etc.,

Types of Resistance Welding

1. Butt welding
2. Spot welding
3. Seam welding
4. Projection welding

1. BUTT WELDING

- Two metal pieces of the same cross section are held together by clamps and pressed.
- A current is now applied through the secondary coil of the transformer.
- Heat is generated at the contact surface and a joint result.
- The weld joint will be bulging and round.
- It has to be machined.
- Fig 4.7 shows resistance butt welding.

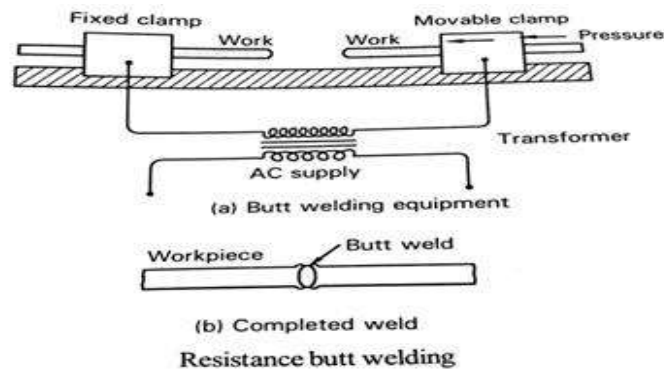

Fig. 4.7 Resistance Butt Welding

Advantages

- Joint obtained is clean, as filler metal is not used in this process.
- Produces defect free joint.
- Oxides, scales and other impurities are thrown out of the weld joint due to high pressure applied at elevated temperatures.

Disadvantages

- The process is suitable for parts with similar cross-sectional area.
- Joint preparation is a must for proper heating of workpiece.

Applications

- Used for producing joints in long tubes and pipes.

2. SPOT WELDING

- It is the simplest form of resistance welding.
- Used for welding sheet metal, both ferrous and non-ferrous metals of 8 mm thick and less.
- Consists of two electrodes (water cooled), one is fixed and other is movable.
- The sheets are cleaned first and are placed between the electrodes.
- Bottom electrode is fixed and the top electrode is movable.
- By operating a foot lever the movable electrode is brought in contact with the sheet and a pressure of 22-25 N/mm² is applied.
- A low voltage of 30-40V and high current of 120-300 amps is passed between the electrodes.
- This results in intense heat and the sheet gets welded within 10-15 sec.
- Soon after the current is switched off with pressure on.
- After the weld cools, pressure is released.
- Materials having higher thermal conductivity can be easily welded.
- Fig. 4.8 shows the details.

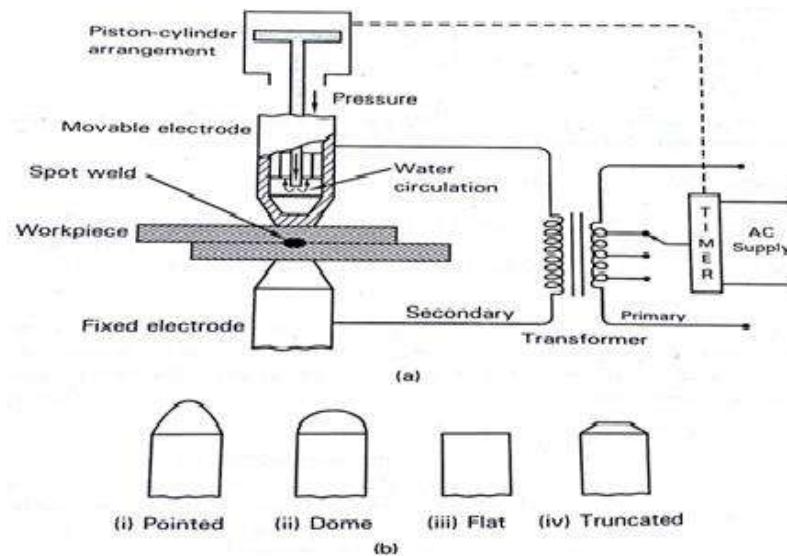

Fig. 4.8 Spot Welding

Spot welding cycle

During one welding cycle there will be 4 different timings involved.

Squeeze time: It is the time (0-1) between the initial application of pressure on the work through the electrode and the initial application of current for making the weld. Full electrode pressure is obtained during the period. Upper electrode comes in contact with it and full pressure is realized. Slowly the pressure is increased and maintained as welding current is applied.

Weld time: Period 1-2, weld current is applied through the electrodes for a known time.

Hold time: The pressure is maintained after welding at full pressure for some time then cooled at point 3.

Off time: It is the time interval from the end of the hold time to the starting of squeeze time for the next cycle.

3. SEAM WELDING

Here two copper wheels act as electrode through which current is passed and pressure is applied.

- Work pieces are kept between the electrodes and current is passed through the electrodes and pressure is applied.
- A weld is formed. Continuous weld is formed as the work is moved between the electrodes.
- Heat is generated due to the flow of current and the work offers resistance to this.
- Either current or pressure can be varied to control the heat generated.
- This changes the contact resistance.
- A series of overlapping welds are formed and the spacing can be controlled by

METAL CASTING AND WELDING

controlling the movement of the work.

- Used for making continuous welds between two overlapping sheets of metal for producing water tight joint.
- Fig. 4.9 shows the details.

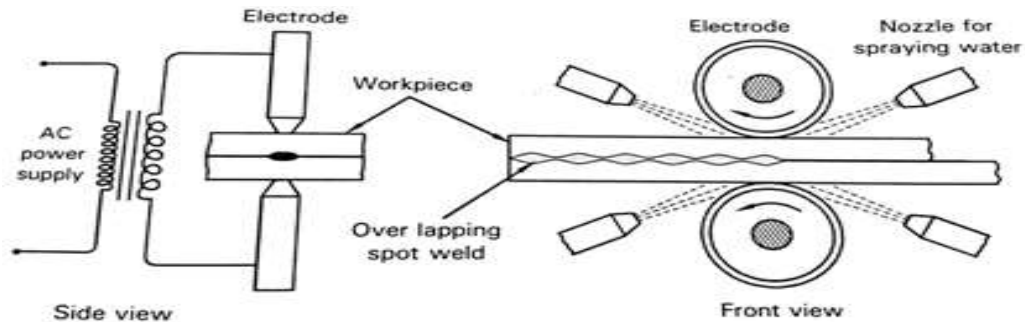

Seam welding process

Fig. 4.9 Seam Welding

PROJECTION WELDING

- It is similar to Spot Welding.
- Copper platens are held in the arms.
- The work pieces are held in position in the arms.
- One piece has projections and the other is flat.
- Current is passed and pressure is applied.
- The projections flatten and the two pieces get welded.
- Large number of welds can be done at various points by having projections.
- Any metal or alloy can be welded.
- Fig 4.10 shows the details.

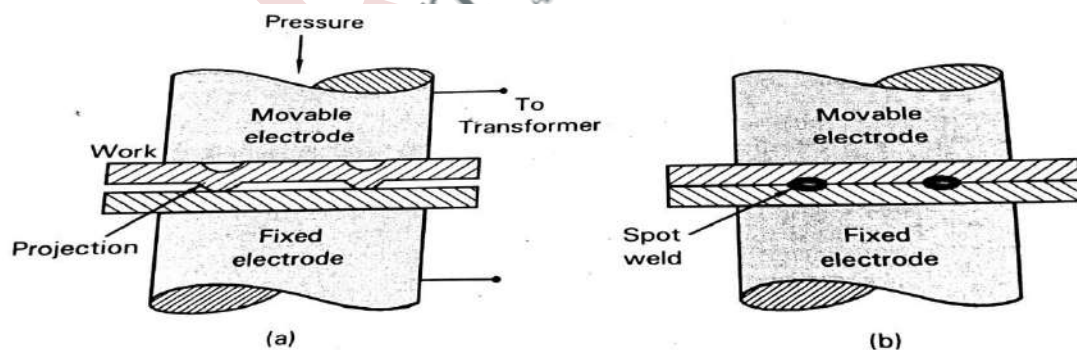

Figure 4.10 Resistance projection welding

FRICITION WELDING

- Heat produced due to friction is utilized and by applying pressure a joint is formed.
- The heat is enough to fuse the work pieces.
- One of the work pieces is held stationary and the other work piece is pressed against it and kept rotating at high speed, a very high pressure is applied and the rotation is stopped.

METAL CASTING AND WELDING

- Perfect joint results.
- No preparation of the surface required. The surfaces to be welded must be flat. Process is well suited to non ferrous alloys.
- Pipes, tubes, bars of carbon steel, stainless steel. Al, Ti alloy, steels can be welded with ease.
- Dissimilar metal can be joined.
- Initial pressure, heating time and final upsetting pressure can be varied to suit the requirement.

Fig. 4.11 shows the details of friction welding.

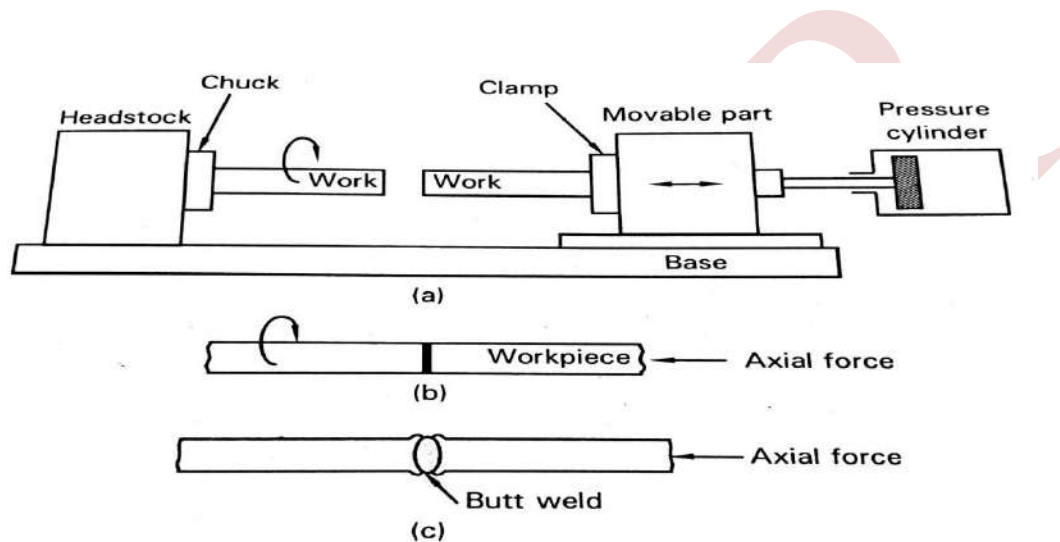

Figure 4.11 Friction welding

EXPLOSIVE WELDING

- Explosive forces generated by the ignition of explosive materials will travel at very high velocities.
- These forces are used to cause ripples in the base metal and lock them together.
- The base metal parts are placed at an angle to each other.
- The parts are covered with flexible rubber and it explosive material is covered.
- The whole arrangement is kept in a special chamber.
- A detonator is used to detonate the explosive material.
- The force of detonation results in ripples in the parts and the shock waves will lock the parts together.
- Like and unlike metals can be joined.
- Normally big items are welded.
- Fig. 4.12 shows the details.

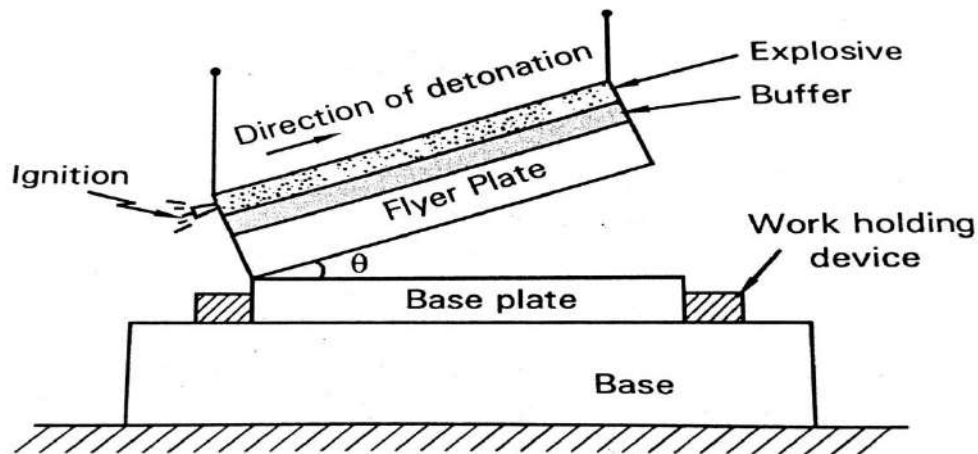

Figure 4.12 Explosive welding

THERMIT WELDING

Thermit welding is primarily a fusion welding process in which the weld is effected by pouring superheated liquid thermit steel around the parts to be welded.

The high temperature obtained from the reaction of finely divided metallic oxide (usually iron oxide) and aluminium is employed to rise the temperature of the parts to be welded to above their fusion point. The liquid metal acts as filler.

- Thermit welding is based on casting & foundry practice.
- It essentially consists of providing, by means of a chemical (thermit) reaction a volume of molten metal which is poured into the joint to be welded. Certain metals are preferentially welded by this method.

Chemical Reaction

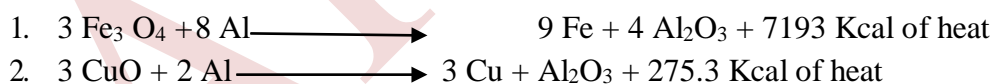

- The chemical affinity of aluminium for oxygen is the basic for the thermit process.
- Thermit reaction is an exothermic one.
- Thermitical temperature from reaction (1) is 3088°C , but due to radiant heat losses and losses to reaction vessel, this temperature is reduced to 2538°C .
- The thermit mixture is ignited with the help of a special ignition powder consisting largely of barium peroxide.
- This in turn is ignited by a burning magnesium ribbon or by a spark.
- Fig. 4.13 shows, Thermit welding process.

METAL CASTING AND WELDING

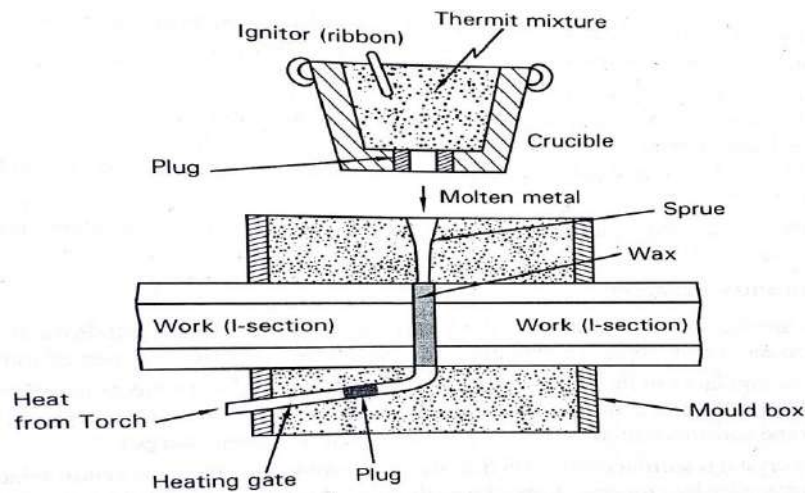

Figure 4.13 Thermit welding

Application of thermit welding:

- Joining of heavy sections.
- Welding of pipe joints.
- Repair field as repair of shafts, machinery frames, etc.
- Welding of railway rails.

Advantages:

- The heat necessary for welding is obtained from a chemical reaction and thus no costly power supply is required.
- Hence broken parts (rail etc) can be welded on the site itself.

Disadvantages:

- Thermit welding is applicable only to ferrous metal parts of heavy reaction i.e., mill housings and railway reactions.
- The process is uneconomical if used to weld cheap metals or light parts.

LASER WELDING (*Laser Beam Welding*)

Lasers are devices which are capable of generating a very intense beam of optical radiation. The word **laser** is an acronym of **L**ight **A**mplification by the **S**timulated **E**mission of **R**adiation.

Laser welding is a process wherein a coalescence beam is produced by the heat obtained from the application of a concentrated light beam impinging upon the surface to be joined.

Principle & Theory of Operation :

- Ruby is Aluminium Oxide (Al_2O_3) with Chromium dispersed throughout, constituting about 1/2000 of the crystal.
- The ends of crystal are silvered to form mirrors internally.
- Around the outside of the crystal are placed flash tubes containing xenon.

METAL CASTING AND WELDING

- This flash tube converts electrical energy into light.
- Capacitor bank stores electrical energy.
- It energizes the flash tube by an appropriate triggering system.
- When subjected to electrical discharge, xenon transforms electrical energy into white light.
- As the ruby is exposed to the intense light flashes, the chromium atoms are excited and pumped to a high energy level.
- The atoms drop immediately to an intermediate energy level with the evolution of heat and eventually back to their original states with the evolution of red fluorescent light.
- As the red light emitted by one excited atom hits another excited atom, the second atom gives off red light which is in phase with the colliding red light wave.
- This becomes a chain reaction and finally a narrow laser beam comes out of the ruby crystal.
- This beam is focused by an optical focusing lens to produce a small intense spot of laser on the job, thereby heating up and melting it to facilitate the welding operation.

Fig. 4,14 shows the details.

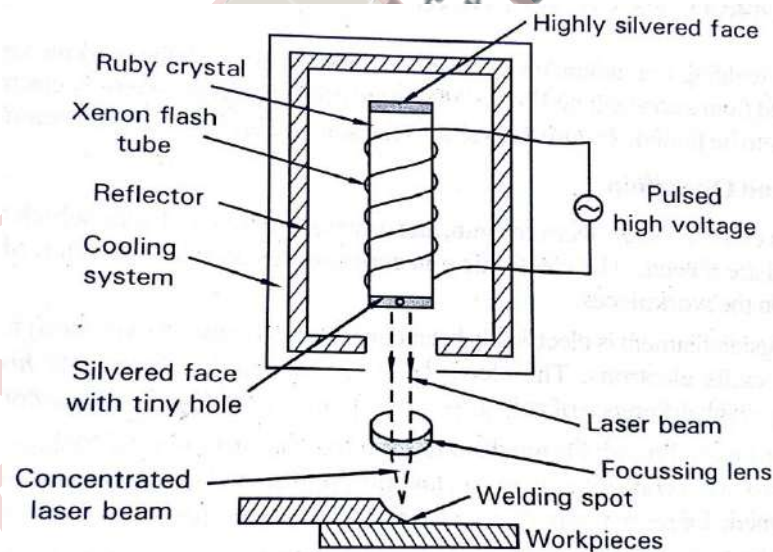

Figure 4.14 Laser welding

Advantages :

- ✓ Welds can be made inside transparent glass or plastic housings.
- ✓ A wide variety of materials can be welded.
- ✓ It permits welding of small, closely spaced components with welds as small as a few microns in diameter.
- ✓ Laser beam being highly concentrated produces narrow size of HAZ.
- ✓ Heat-treated alloy can be welded without affecting their heat treated condition.

METAL CASTING AND WELDING

- ✓ As no electrode is used, electrode contamination is eliminated.
- ✓ Since it is light, it can be focused to microscopic dimensions and directed with great accuracy.
- ✓ The laser beam concentrated energy can be precisely controlled.
- ✓ Areas not readily accessible can be welded.
- ✓ No protection is needed against atom contamination.

Disadvantages :

- The major drawback is the slow welding speeds (25 to 250 mm/min) resulting from the pulse rate and puddle sizes at the fusion point.
- It is limited to depths of approximately 1.5 mm and additional energy only tends to create gas voids and undercuts in the weld.
- Materials such as Mg tend to vaporize and produce severe surface voids.

Applications :

- Laser is a high energy light beam that can both welded and cut the metals.
- For connecting leads on small electronic components and in integrated circuitry in the electronic industry.
- To weld lead wires having polyurethane insulation without removing the insulation.
- To join hard high melting polyurethane metal alloys.
- In space and aircraft industry for welding light gauge materials.
- It can join dissimilar metals and other difficult metals to weld such as Cu, Ni, Al, Ti, stainless steel, zirconium, tantalum, etc.
- Laser can weld wire-to-wire, sheet-to-sheet, wire-to-sheet, tube-to-sheet and small diameter stud welds.
- Laser beam is used for micro welding purposes.
- It's particularly suitable for the welding of miniature and micro-miniature size components.

(The operation is similar to that, when the sun rays are made to concentrate on a single spot on a paper, which is placed below a magnifying lens, the paper burns. The laser energy source is a refinement of this process)

ELECTRON BEAM WELDING (EBM)

Principle & Theory of Operation :

- Heat is generated by focusing a stream of highly accelerated electrons on the work piece.
- The temperature realized is sufficient to melt.
- Welding can be easily carried out. Electron beam welding is a fusion welding process.
- High velocity electrons are made to strike the metal.

METAL CASTING AND WELDING

- The kinetic energy of the electrons gives almost completely into heat. This heat melts and fuses the metal.
- An electromagnet is used to focus the beam of electron accurately.
- A heated filament is used as a source of electrons which are made to flow through a circular ring shaped anode.
- An electromagnetic coil is used to focus the electron beam and is made to fall on the workpiece to be welded.
- The workpiece itself is placed in a vacuum chamber. Provision is made to move the workpiece.
- A tungsten filament which serves as a cathode emits a mass of electron that are accelerated and focused to a 0.25 to 1 mm diameter beam of high energy density upto 0.5 to $10\text{kW}/\text{mm}^2$.
- The heat generated is about 2500°C .
- This is sufficient to melt and vaporize the workpiece material and thus fills a narrow weld gap even without a filler rod.

Construction:

- Electron Beam Welding set up consists of electron emitting and accelerating unit beam focusing unit, a vacuum chamber to hold the workpiece.
- A vacuum of 10^{-4} to 10^{-2} mm of Hg is used.
- The penetrating power of electron beam depends on the speed of electron which in turn is controlled by the accelerating unit (15-30 KV DC).
- Electron beam welds are very narrow and the energy density is nearly $5 \times 10^8 \text{W}/\text{mm}^2$.
- Fig. 4.15 shows the details of Electron Beam Welding

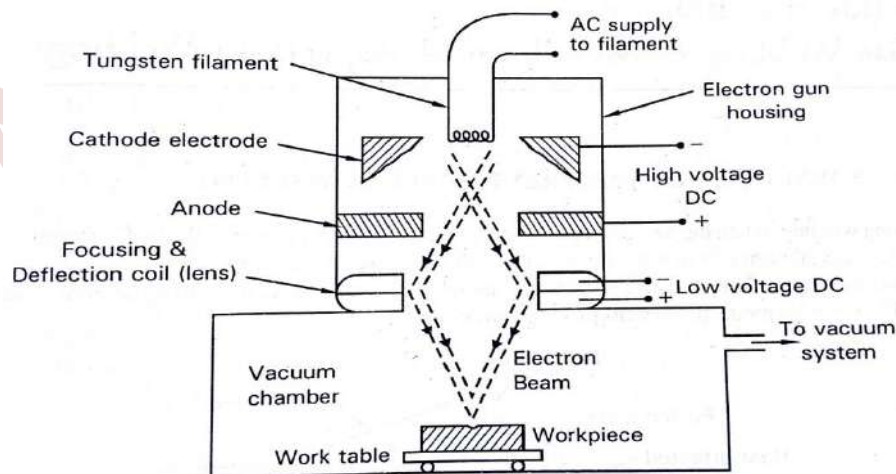

Figure 4.15 Electron beam welding

Working:

- Joint preparation of workpiece is very important to get a sound weld.
- The edges are to be cleaned thoroughly, free of oxide, dust, grease, etc.

METAL CASTING AND WELDING

- The work pieces are demagnetized before welding.
- They should be free from residual magnetism or else the electron beam gets deflected.
- The residual magnetism can be removed by placing the work piece in an inductive field of 50 cycles frequency.

Merits :

- Heavy sections upto 100 mm thick stainless steel can be welded easily.
- Very thin sections of 0.025 mm can be welded.
- Control of welding is easy.
- Narrow welding can be done.
- Neat welding can be done.

Demerits :

- ✓ Size of workpiece is limited. Initial cost of equipment is high.
- ✓ Skilled operators are required.
- ✓ The workpiece should be electrically conductive in nature.

Application :

- Used for welding super alloys, refractory metals, reactive metals and stainless steels.
- Titanium, beryllium, molybdenum and zirconium components are welded.
- Used in aircraft, automobile industry, farm equipments, electronics, missile industry.
- Used for welding gears, cams, etc.

EDGE PREPARATION

Before starting the welding process, the edges of the two workpieces to be welded should be prepared well to obtain a sound weld. This process is called edge preparation and involves two operations:

- (a) Preparation of joint and
- (b) Cleaning of joint.

(a) Joint preparation

Joint preparation involves cutting or beveling the edges of the two workpieces to suitable shapes so that heat would be able to penetrate to the entire depth of the workpiece. Figure 4.1 shows the different shapes that can be prepared based on the application.

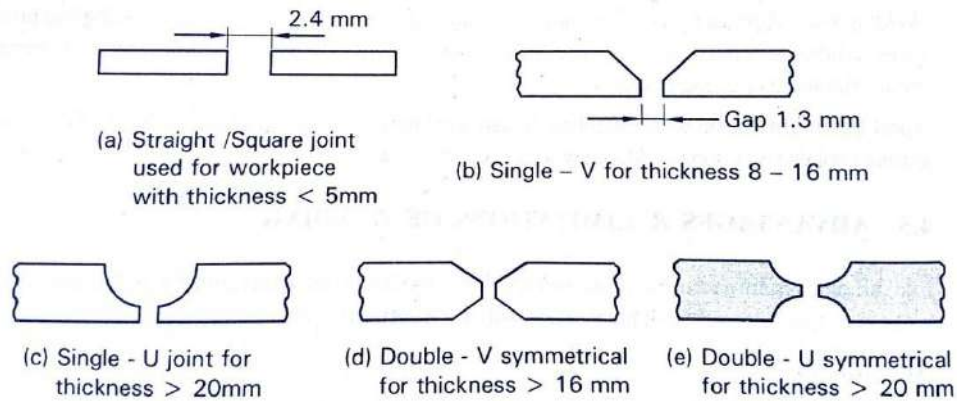

Figure 4.1 Edge preparation

Figure 4.1(a) shows a square or straight joint suitable for workpieces with thickness less than 5 mm. Some workpieces are beveled only on one side, as in single-V or single-U joints, but for very thick plates, beveling is required on both sides as shown in figure 4.1 (d) and (e).

(b) Cleaning of joint

Workpiece surfaces are often chemically contaminated by dirt, grease, oxides etc. Most metals are very reactive, and in air, they become coated with an oxide layer or with adsorbed gas. This layer prevents intimate contact from being made between the two metal surfaces. Hence, the edges of the workpieces and the area adjoining them should be cleaned thoroughly to remove the contaminants.

Cleaning is done either chemically by using acetone or carbon tetrachloride solution or mechanically by using wire brush, hand files or grinding process.

MODULE 5

SOLDERING, BRAZING AND METALLURGICAL ASPECTS IN WELDING

Formation of different zones in welding

During welding, when the heat interacts with the workpiece material, the flow of temperature in the material varies from region to region resulting in three distinct regions or zones, they are the fusion zone, heat affected zone and the unaffected base metal zone. (fig 5.1 shows the details)

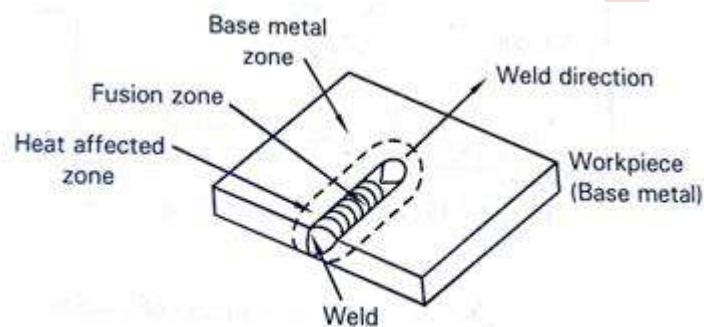

Figure 5.1 Different zones in welding

Zone 1 Fusion zone

Fusion zone is the weld metal itself; more specifically, it is the region where the molten metal of the filler rod combines with the molten metal of the workpiece to form the weld. The fusion zone can be considered similar to a casting process, wherein the workpiece metal reaches the molten state and then allowed to cool. Hence, the metal in the fusion zone has basically, a cast structure with the microstructure reflecting the cooling rate in the weld. The properties of the fusion zone depend primarily on the filler metal used and its compatibility with the workpiece material.

Zone 2 Heat Affected Zone (HAZ)

The fusion zone is surrounded by the heat affected zone, the portion that was not melted, but subjected to elevated temperatures for a brief period of time. As a result, these portions experience changes in its microstructure and mechanical properties. The extent and magnitude to which the changes occur depend primarily on the type of the base metal, and the amount of concentration of heat input at the joint. The metal in this area is often weaker than both the *base metal* and the *weld metal*, and it is also where residual stresses are found.

Zone 3 Base metal zone

Base metal zone is the portion around the heat affected zone which remains unaffected, as it was not heated sufficiently to change its microstructure.

Structure of welds

During welding, a small portion at the edges of the workpiece (fusion zone) will be *melted* followed by immediate and *fast cooling* of the molten metal. Hence, the microstructure development in this region depends on the solidification behavior of the molten metal.

The solidification process is similar to that in casting and begins with the formation of *columnar (dendritic) grains*. Fig. 5.2 shows the grain structure in a deep weld. Along the fusion line, the growth rate is low, while the temperature gradient is steepest. Grains appear at the line of fusion, and as the weld centerline is approached, the growth rate increases while the temperature gradient decreases. Consequently, the microstructure that develops varies noticeably from the edges to the centerline of the weld.

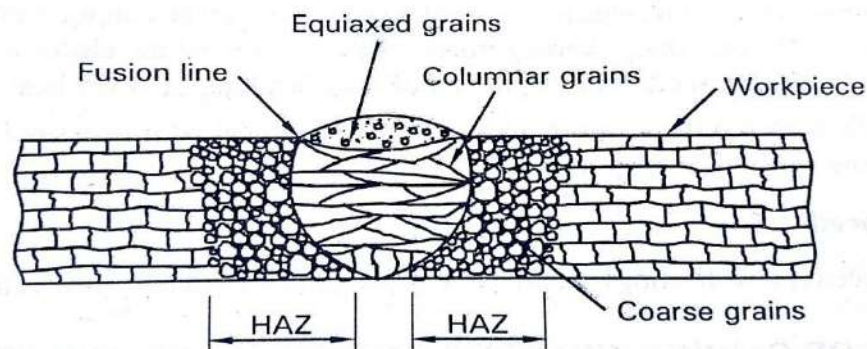

Figure 5.2 Structure of a weld

The grains formed are relatively long and parallel to the heat flow. The grain structure and size depend on the type of welding process employed, filler metal used, and the alloy (metal) being melted.

Adjacent to the portion of the weld metal i.e., in the heat affected zone, coarse grains are formed as a result of overheating. The grain growth will cause this portion to be brittle thereby making it the weakest portion in the weld metal.

Heat Affected Zone

Welding makes use of intense heat to melt the edges of the workpiece material being joined. But during welding, the portion of the base metal adjacent to the edges being joined also gets heated to varying temperatures. As a result, these portions experience changes in its microstructure and mechanical properties. The extent and magnitude to

which the changes occur depends primarily on the type of base metal, and the amount and concentration of heat input at the joint.

Thus the heat affected zone can be defined as that portion of the base metal which has not been melted, but, whose microstructure and mechanical properties have been altered by the heat of welding. The heat affected zone is often the weakest part in the welded metal, because it neither possesses the properties of the base metal nor that of the solidified welds metal. Consequently, heat affected zone forms the region for most of the failures of the welded joint. However, the heat affected zone can be reduced by controlling a few parameters described below:

a. Thermal diffusivity

The thermal diffusivity of the base material plays a large role: if the diffusivity is high, the material cooling rate will be high, and hence the heat affected zone will be relatively small. Low diffusivity leads to slower cooling and a larger heat affected zone.

b. Heat input

Processes like oxy-fuel welding, electroslag welding etc., use high heat input thereby increasing the size of the heat affected zone, whereas processes like laser welding, electron beam welding etc., give a highly concentrated, limited amount of heat resulting in small heat affected zone.

Arc welding falls between these two extremes with the individual processes like TIG, SAW, etc., varying somewhat in heat input.

c. Welding speed

Slow welding speeds (slow heating causes slow cooling rates and a large heat affected zone).

Effect of carbon content on structure and properties of steel

Steel is most widely used material in welding compared to other materials. Steel may be defined as refined pig iron, or an alloy of iron and carbon. Various elements like sulphur, manganese, phosphorous, etc., are added to steel in order to impart the properties like hardenability, strength, hardness, weldability, wear resistance, etc.

Of all the constituents, carbon is the most ingredient in steel, because it has a direct effect on the physical properties of steel.

Shrinkage in welds

Welding involves highly localized heating of the metals being joined together. During welding, when the weld metal is deposited, the base metal is heated, and thus it

expands, but on cooling the base metal plus the weld metal shrinks. It is obvious that the shrinkage of a welded joint is far greater than the expansion. This shrinkage in turn introduces residual stress distortion which is a major problem in welding.

Shrinkage is the inherent property of any metal, and hence cannot be prevented, but can be controlled. There are various methods that can be used at the design stage, or in welding shops to minimize the effects caused by shrinkage. These include:

a. Do not over weld

The more metal placed in the joint, the greater is the shrinkage forces. Hence, use of right joint preparation avoids excessive gap thereby requiring least amount of weld metal. (Refer Fig. 5.3.a)

b. Use intermittent welding

Another way to minimize weld metal is to use intermittent welding rather than continuous welds. (Refer Fig. 5.3.b)

c. Use as few weld passes as possible

Fewer passes with large electrode are preferable to a greater number of passes with small electrodes. This helps to minimize shrinkage. (Fig. 5.3.c)

d. Place welds near neutral axis

Attempts regarding placing welds near the neutral axis should be done at the design stage itself. Fig. 5.3.d

e. Balance welds around the neutral axis

This practice, will balance one shrinkage force against another thereby minimizing distortion of the weldmate. Fig. 5.3.e

f. Balance shrinkage forces with opposing forces

Pre-bending, as shown in Fig. 5.3.f, makes use of opposing mechanical forces to counteract distortion due to the shrinkage effect. Clamps, jigs or fixtures may be used to hold the workpiece until welding is completed. When the clamps are released, the plates return to the flat shape allowing the weld to relieve its shrinkage stresses.

g. Removing shrinkage forces after welding

One method involves peening or hammering the weld metal with a blunt rounded edge that will cause the weld bead to stretch and make it thinner, thereby relieving the stress induced by shrinkage. But, peening may cause damage to the weld metal and hence has to be used in special cases.

Another method is by thermal stress relieving or heat treatment technique, wherein, controlled heating of the weld metal to elevated temperature is followed by controlled cooling. The residual; stresses that would tend to distort the weldments are thus

minimizes.

h. Minimise welding time

It is desirable to finish the weld quickly, before a large volume of the surrounding metal heats up and expands. This helps to minimize the shrinkage effects.

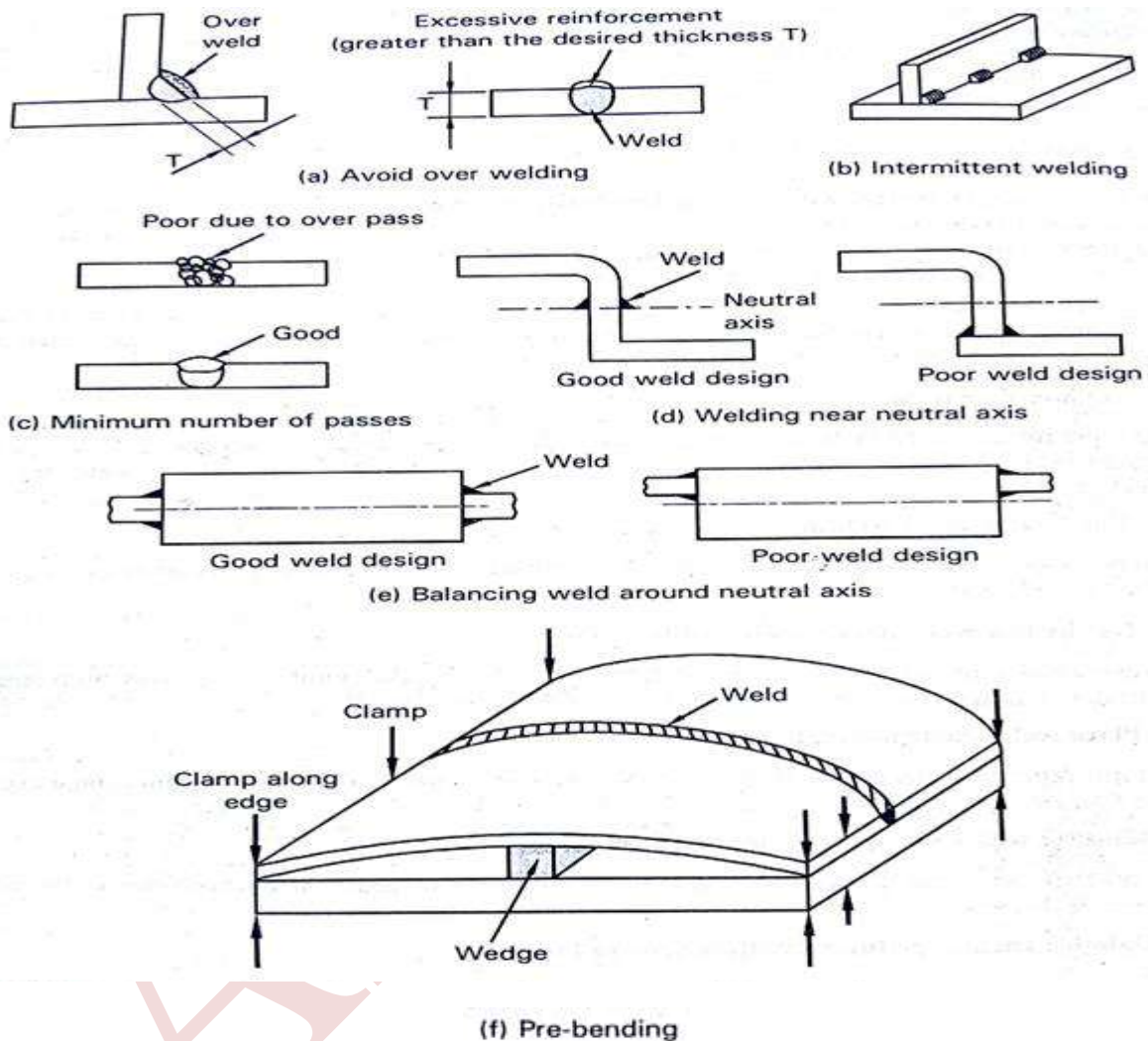

Figure 5.3 Methods to minimize shrinkage effects

Residual stresses

During welding, the metal expands due to heating, and upon cooling, the weld metal solidifies and shrinks, exerting stresses on the surrounding weld metal. In other words, the heating and cooling of the weld metal induces residual stresses in the material. Residual stresses remain in a body (material) and are independent of any applied load.

Effects of residual stresses

- a. Residual stresses can result in visible distortion of a component
- b. Residual stresses can reduce the strength of the base material and can lead to catastrophic failure through cold cracking.
- c. Lowers the ductility of the metal.
- d. Residual stresses may increase the rate of damage by fatigue, creep or environmental degradation.

Control of residual stresses

- a. Residual stresses are minimized by reducing the amount of weld metal deposited. Since residual stresses result from the restrained expansion and contraction that occur during welding, the lower the weld metal deposited, the lower will be the induced stress. Example: use of U-groove instead of V-groove consumes less weld metal.
- b. Reduce the amount of heat input at the joint.
- c. Welding sequence used should not be from one end directly to the other, but, rather in segments.

Relieving residual stresses

Two commonly used methods for relieving residual stresses are discussed below:

a. Peening:

Peening or hammering of the weld metal with a blunt rounded edge will cause the weld bead to stretch and make it thinner, thereby relieving the stresses induced by shrinkage. Peening should be employed on those weld metals possessing sufficient ductility to undergo necessary deformation. Also, peening should be employed carefully so that it will not cause damage to the weld metal.

b. Heat Treatment

Heat treatment (example: Annealing) is a thermal stress relieving technique that employs controlled heating of the weld metal usually in a furnace, followed by controlled cooling so as to relieve the stresses induced in the weld metal. The metal is cooled slowly either inside the furnace or in atmospheric air up to room temperature.

Weldability

- It is the easiness with which a metal can be welded into reliable inseparable joint having proper structure and property.
- Metals with limited solid solubility have lower weldability.
- Metals which are insoluble in each other in the solid state are entirely unweldable by fusion welding.
- Such metals are heated to a plastic state and then a mechanical force is applied to make the bonding between parts.
- In some cases a third metal is introduced at the joint, which is soluble in the metals.
- Metals having higher thermal conductivity are most easily weldable.
- They dissipate heat from the weld fast.

The main problem associated with weldability is the development of cracks in:

The welded portion i.e., the joint

*The common surface between the weld metal and the parent metal
The parent metal adjacent to the weld.*

Welding results in heating of the parent metal and is suddenly exposed to atmosphere air. This brings about sudden cooling. This induces hardening in the metal and reduces ductility. This induces cracking tendency.

The following factors affect weldability of metal:

- Thermal conductivity of metal
- Thermal expansion of metal
- Microstructural changes in the metal
- Oxidation of the metal
- Surface condition of the metal.

Weldability of metals in descending order:

Wrought Iron (pure iron) Carbon steel
(<0.25%C) Cast iron
Low alloy steel Stainless steel

Concept of Filler metal, Electrode & Flux

A filler metal is a metallic wire used to supply additional material to fill the gap between the two workpieces to be joined. The filler metal is available in the form of rod, and is made of the same material or nearly the same chemical composition as that of the base metal. The filler metal used in arc welding processes is called electrode.

Filler metal is classified into three basic categories:

- i. Coated electrode
- ii. Plain/Bare or uncoated electrode
- iii. Fabricated tubular or cored electrode wire

i. Coated electrode

In coated electrodes, the metallic wire, called core is coated with a flux, Fig. 5.4(a) Coating is done by dipping the heated end of the filler rod in the constituents of flux. The flux sticks to the metallic wire. The detailed description regarding flux coating is provided herein.

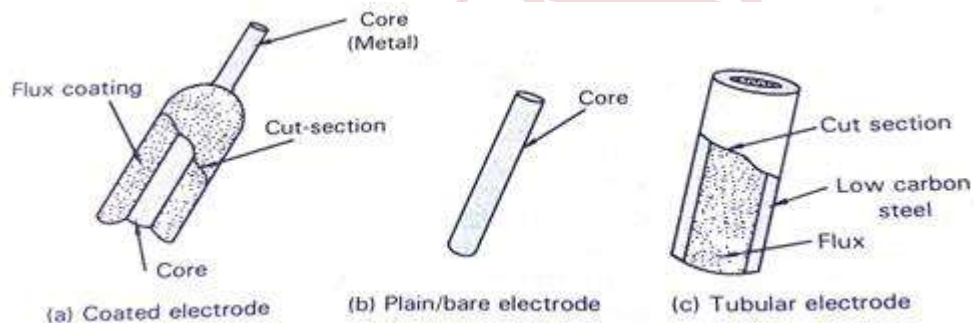

Figure 5.4 Filler metals / Electrode

During welding, the workpieces melt and at the same time, the tip of the electrode also melts. As the globules of molten metal pass from the electrode to the workpiece, they absorb oxygen and nitrogen from the atmospheric air. This causes the formation of some non-metallic constituents which are trapped in the solidifying weld metal, thereby decreasing the strength of the joint. In order to avoid this, a flux is coated on the metallic wire. During welding, the flux vaporizes and produces a gaseous shield around the molten weld pool, thereby preventing atmospheric contamination.

The original purpose of the coating was to provide shielding from the oxygen and nitrogen in the atmosphere. It was subsequently found that ionizing agents could be added to the coating which helped to stabilize the arc and made electrodes suitable for welding with alternating current (AC). The flux coated on the electrode performs a variety of functions depending on the constituents from which it is made. Various constituents, like titanium oxide, cellulose, manganese oxide, calcium carbonates,

mica, iron oxide, etc., are used as flux materials for coating.

Functions of Flux

- Prevents oxidation of molten metal
- Helps in removal of oxides and other undesirable substances present on the surface of the workpiece.
- Chemically reacts with the oxides and forms a slag. The slag floats and covers the top portions of the molten metal thereby preventing it from rapid cooling.
- Stabilizes the arc.
- Eliminates weld metal porosity.
- Minimum spatter adjacent to the weld.

ii. Plain/Bare or uncoated electrode

In this type of filler metal, the metallic wire (core wire) is left plain or uncoated with flux Fig. 5.4.(b). These electrodes do not prevent oxidation of the weld, and hence the joint obtained is weak. Welding processes that makes use of bare electrodes utilize inert gases for shielding of weld metal during welding. MIG, SAW and other processes make use of bare electrodes.

Bare electrodes in the form of wire were first used for oxy-fuel gas welding processes to supply additional materials to fill the joint. Later on, the wire was provided in coils for automatic welding process. Bare electrodes are so named, because they are uncoated with flux material. However, a very thin copper coating is provided on the wire to improve current pick-up and also prevent rusting of the wire.

iii. Tubular wire

Tubular electrodes are hollow materials containing flux constituents inside and are used in flux-cored arc welding process. The tubular electrode consists of a wire made of a low- carbon steel sheath surrounding a core of flux and alloying materials. The compounds contained in the wire perform essentially the same functions as the coated electrodes.

Electrodes

A welding electrode is defined as a component of the welding circuit through which current is conducted. In other words, the electrode forms one pole of the electric circuit, while the workpiece forms the other pole. Welding electrodes are classified into two types:

- a. Consumable electrodes and

b. Non-consumable electrodes

a. Consumable electrodes

Consumable electrodes are those which get consumed during the welding process. These electrodes help to establish the arc and also act as filler metal to deposit additional material to fill the gap between the workpieces. Consumable electrodes may be coated, bare or tubular type.

b. Non-consumable electrodes

Non-consumable electrodes are those which are made of carbon, graphite or tungsten and do not consume during welding. They serve only to strike and maintain the arc during the welding process. TIG, Atomic hydrogen welding process, etc., use non-consumable electrodes.

Welding Defects

Like casting, welding also involves various parameters, viz., type of workpiece material, electrode material, power source, heat input, cooling rate, welding speed, etc. Loss of control in any of these parameters may cause defects in the weld metal. Most of the defects encountered in welding are due to improper welding procedure. Some of the common defects and their causes are discussed below:

a. Crack

Crack is a small, sharp split that occurs in the base metal, weld metal or at the interface between the two and are visible to the naked eye. Crack is a serious defect because they are seen as stress raisers capable to grow until fracture takes place.

Causes

- Incorrect technique for ending the weld
- Poor ductility of the based metal
- Combination of joint design and welding techniques, which results in a weld bead with an excessively concave surface that promote cracking.
- Low welding currents.
- Restrained joints – joint members are not free to expand and contract when subjected to heat.

b. Distortion

Distortion is the change in the original shape of the two workpieces after welding.

Causes

- High residual stresses due to
- shrinkage High heat input
- More number of passes
- Slow welding speed

c. Incomplete penetration

When the molten metal fails to penetrate the entire thickness of the base plate, it forms a bridge across the two plates causing a defect in the weld. Fig

Causes

- Improper joint design
- Low welding current
- Slow arc travel speed
- Incorrect torch angle

d. Inclusions

Inclusions are usually non-metallic particles such as slag or any foreign material that does not get a chance to float on the surface of the solidifying metal and thus gets trapped inside the same Fig.

Causes

- Use of large electrodes in a narrow groove
- Low currents that are insufficient for melting
- metal High viscosity of the weld metal.

e. Porosity

Porosities are small voids or cavities are formed when gases are trapped in the solidifying weld metal. Porosity can occur either under or on the weld surface. Fig. 8(e).

Causes

- Atmospheric contamination caused due to inadequate shielding gas.
- Excessively oxidized workpiece surface
- Use of wet electrodes
- Excessive gases released during welding.

f. Under cut

Under cut, the worst of all defects is the term given to a sharp narrow groove along the toe of the weld due to the scouring action of the arc removing the metal and not replacing it with the weld metal. Fig.

Causes

- High voltage and welding current
- High arc travel speed
- Incorrect electrode manipulation
- Arc gap too long

g. Lack of fusion or overlapping

Lack of fusion is the failure of a welding process to fuse together layers of the base metal. The weld metal just rolls over the workpiece surface. Fig.

Causes

- Low welding currents that are insufficient to raise the temperature of the workpiece

metal to melting point.

- Excessive surface impurities of workpiece.
- Improper electrode type/size.
- Wrong polarity.
- Low arc travel speed.

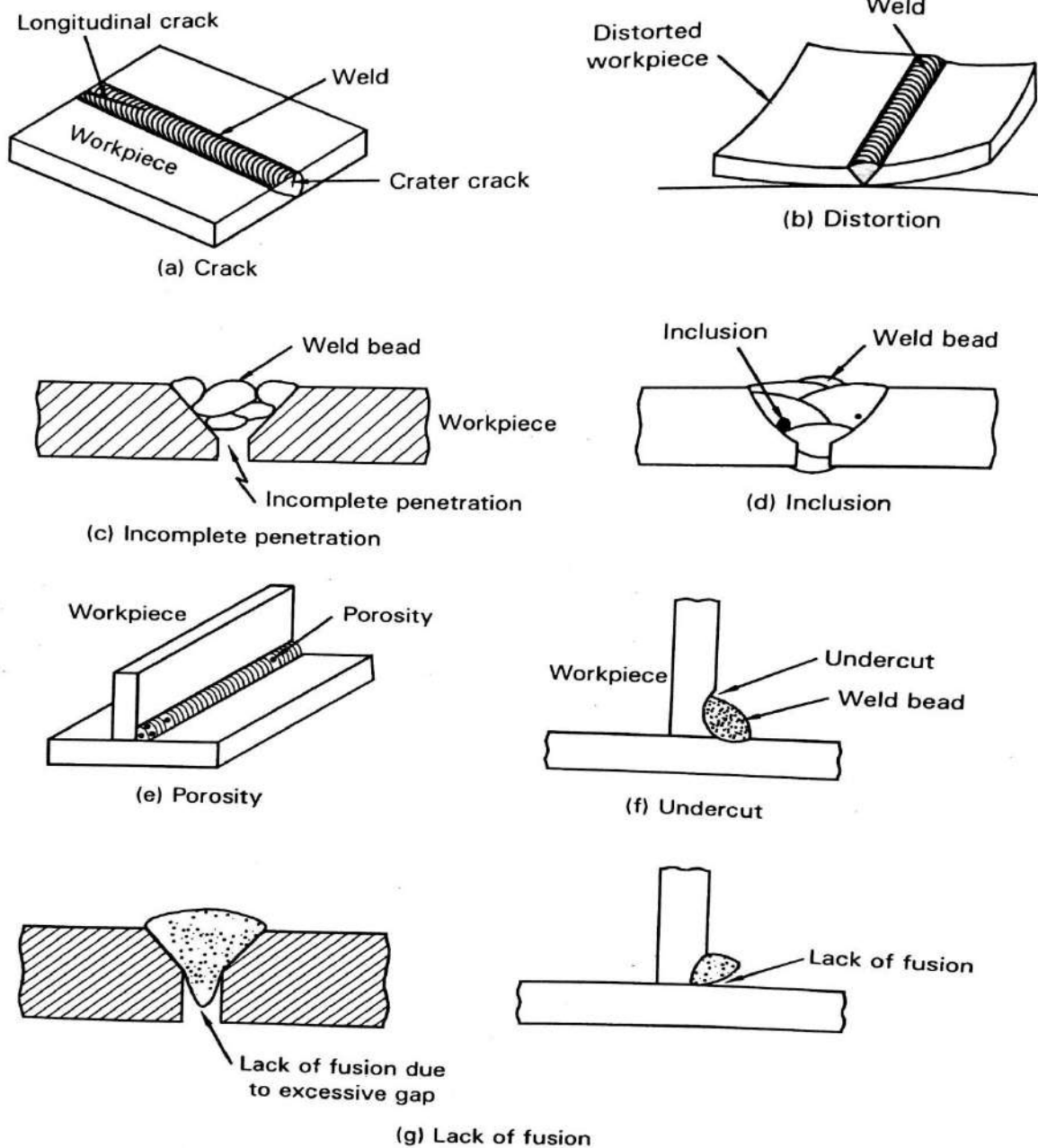

Figure 5.5 Welding defects

GAS WELDING

- Gas welding is a **fusion** welding process.
- Here the heat is generated by the combustion of **oxygen** or air and a **gas** (such as acetylene, hydrogen, butane, methane petroleum gas, etc) is used to join metals.
- A strong flame is produced when the mixture of gases are ignited.
- This flame has a very high temperature which melts and fuses the metal parts. The quantities of gases are to be regulated for controlling the weld flame.
- A **filler metal** rod is used to supply molten metal at the joint.
- Gas torch is used for welding hence is referred to as **welding torch** also.
- It is used for repair work, for joining thin walled parts of steel and non-ferrous alloys. Two familiar fuel gases used in gas welding are:
 - Mixture of **oxygen** and **acetylene** gas – called **oxy-acetylene** welding process. Mixture of **oxygen** and **hydrogen** gas – called **oxy-hydrogen** welding process.
 - Oxy-acetylene welding is the most versatile and widely used gas welding process due to its high flame temperature (upto 3200°C) when compared to oxy-hydrogen process (2500°C).

Reaction in gas welding

The details of reaction involved at each step and the final equation is given below.

First acetylene is decomposed to C and H

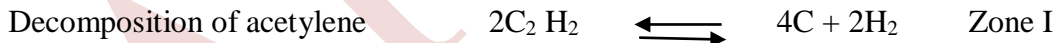

Then the carbon combines with oxygen to form CO due to partial combustion

Incomplete combustion

Finally CO is converted to CO₂ due to complete combustion

Combustion of CO to CO₂

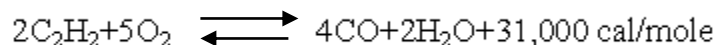

Zone I Consists of decomposed products of C₂H₂. A truncated cone flame with rounded end is formed. Solid carbon particles are formed which are incandescent, glow with the brightest flame.

Zone II Heat is evolved mainly due to oxidation of C to CO at a distance of 3-5mm from the end of the inner cone.

Temperature is the highest in this zone greater than 3000°C.

In this reducing zone, the products of combustion CO and H₂ can reduce oxides.

Zone III In this oxidizing zone, CO is burnt and H₂ to water vapour with a surplus) from air.

Flame Characteristics

- When acetylene is mixed with oxygen in correct proportion and ignited a flame is produced.
- The flame will have a temperature of 3200°C.
- A gas torch is used for the purpose.
- Acetylene gas is let out through the torch and ignited first.
- The gas catches fire and a flame is produced.
- Oxygen is then let out to sustain the flame.
- By regulating the control valves the quantities of both the gases can be adjusted, so that desired flame is produced.

Three types of flames can be produced. Fig. 5.7 shows the types of flame.

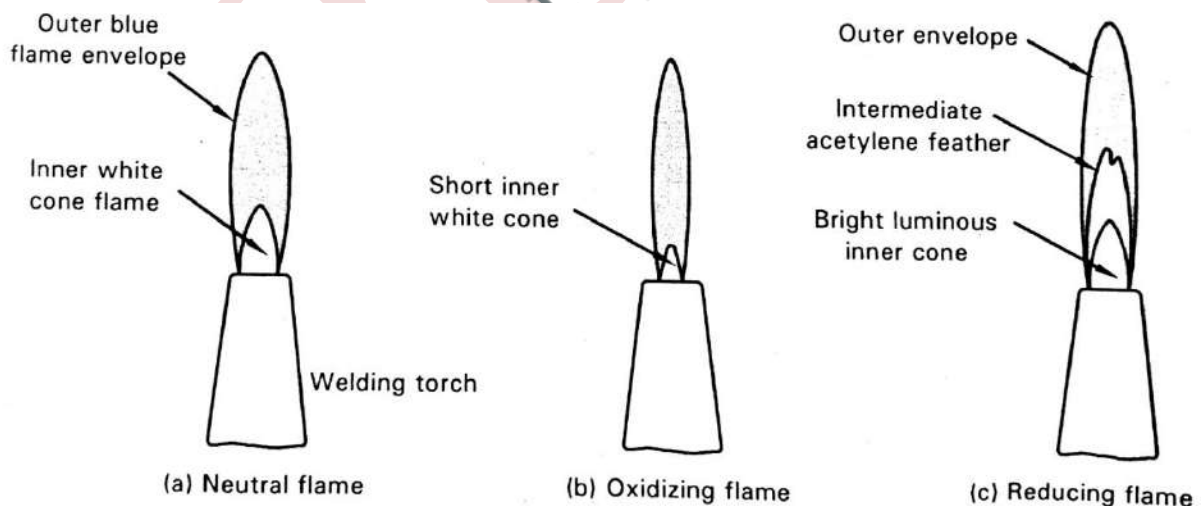

Figure 5.7 Types of flames in gas welding process

1. Neutral Flame : (Oxygen : Acetylene :: 1:1)

- Approximate volumes of gases are in equal proportions.
- Temperature of the flame is about 3260°C. Flame is light blue in colour.

- It is surrounded by outer flame produced by the combination of oxygen and Co , H_2 in the inner zone.
- This type of flame does not bring about any chemical change in the molten metal.
- This type of flame is used for welding mild steel, cast iron, aluminium, copper and stainless steel.
- This is the correct flame for welding.

2. Oxidising Flame : (*Oxygen : Acetylene :: 1.5:1*)

- After establishing neutral flame, if the oxygen content is further increased the resulting flame is oxidising in nature.
- The flame will be small short cone, dark blue in colour and more pointed than in the first case.
- The outer envelope is much shorter than the first.
- The temperature rise is as high as 3480°C .
- The excess oxygen at high temperature tends to combine with many metals to form hard, brittle low strength oxides.
- This type of flame finds limited use in welding.
- A slightly oxidising flame is used in welding copper base alloys, zinc base alloys.

3. Reducing flame : (*Oxygen : Acetylene :: 1:1.5*)

- After establishing neutral flame, if the volume of acetylene gas is increased then the resulting flame is reducing in nature.
- The outer flame envelope is longer than that of neutral flame and is usually much brighter.
- A reducing flame does not completely consume the available carbon, therefore the temperature is lower and the un-consumed carbon is forced into the molten metal.
- A reducing flame ensures the absence of oxidation, metals that tend to absorb carbon should not be welded with this flame. Ex. Non-ferrous, high carbon steels.
- A carburizing flame contains excess acetylene than a reducing flame.

Gas torch construction and working

A gas torch is required for gas welding. The details of gas torch are given below. Fig. 9. Show the details.

- A metal tube „P“ is attached with a detachable end „A“.
- This end carries a mixing chamber „B“ for mixing the gases.
- The mixer is connected to a metallic tube called the tip.
- To the tip is attached a nozzle through which gas mixture comes out.
- Tube „P“ has separate passages for the entry of O_2 and C_2H_2 .
- The passages are connected to the gas cylinders through separate hard rubber hose

tubes.

The quantity of gas can be controlled by valves, independently.

- The pressure of gases are controlled at the cylinder end by operating the regulator and observing the gauges meant for the purpose.
- O_2 enters through the central hole and C_2H_2 enters through the outer holes in the mixing chamber.
- O_2 gas is delivered at pressures approximately 0.17 N/mm².
- C_2H_2 gas is delivered at pressures 0.07 – 0.1 N/mm².

Oxy-acetylene welding

- When the acetylene is mixed with oxygen in correct proportion and ignited a flame is produced. The flame will have a temperature of about 3200°C.
- A gas torch is used for the purpose.
- Acetylene gas is let out through the torch and ignited first.
- The gas catches fire and a flame is produced.
- Oxygen is then let out to sustain the flame.
- By regulating the control valves the quantities of both the gases can be adjusted, so that the desired flame is produced.

Fig. 5.6 shows the oxy-acetylene welding.

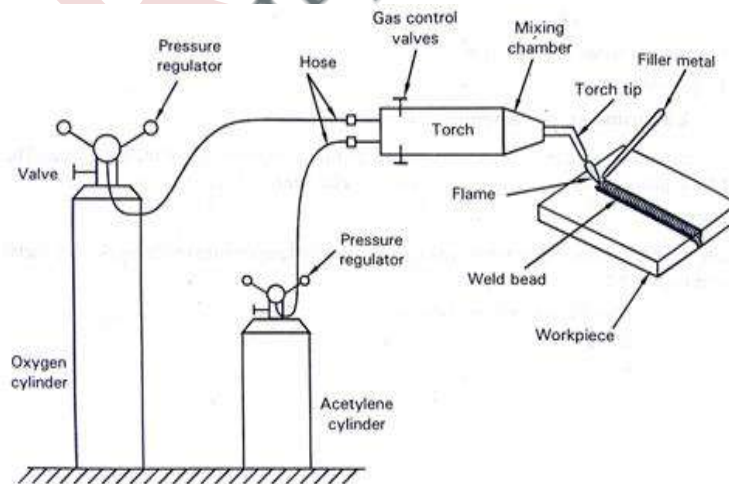

Figure 5.6 Oxy-acetylene welding

Description & Operation

- b. The equipment consists of two large cylinders: one containing oxygen at high pressure and the other containing acetylene gas. Pressure regulators are fitted on the respective cylinders to control the pressure of the gas to the welding torch.
- c. A welding torch having controlling knobs which mixes both oxygen and acetylene in proper proportions and burn the mixture. A spark ignites the mixture at its tip.
- d. The resulting flame at the tip having a temperature of 3200°C which is sufficient enough to melt the workpiece. A slight gap usually exists between the two workpiece, a filler metal is used to supply the additional material to fill the gap.

Advantages

- ✓ Process is simple
- ✓ Controlling temperature is easy.
- ✓ Easy maintenance.
- ✓ Equipment is portable.
- ✓ Eliminates skilled operator
- ✓ Temperature of the flame can be controlled depending upon the type & thickness of the material.

Disadvantages

- Cannot be used for heavy section.
- Flame temperature is less than the arc temperature.
- Acetylene gas is highly explosive and expensive.

Applications

- For joining thin section.
- Most of the ferrous & non-ferrous can be gas welded. Automotive & aircraft industries in sheet metal joining.

5.11 OXY-HYDROGEN WELDING

Oxy-hydrogen welding was the first gas welding process to be developed commercially using a combustion mixture of Hydrogen (H₂) and oxygen (O₂) for producing gas welding flame. The temperature of the hottest part of the flame suitable for welding is around 2500°C against 3200° of an oxy-acetylene flame. The low temperature flame thus obtained was used for cutting and welding thin sheets and low melting point alloys like aluminum, magnesium, lead, etc., and also in some brazing work. Although the temperature of the flame can be varied by varying the oxygen supply, the flame becomes quite unsuitable for welding and as such the proportions of the gas mixture is nearly fixed at a particular value. Further, there is no distinguishing colour to judge the variation in gas proportions as in the case of oxy-acetylene process.

Theoretically, a ratio of 2:1 hydrogen to oxygen mixture (reducing atmosphere) is enough to achieve maximum efficiency, however in practice a ratio 4:1 or 5:1 is needed to avoid an oxidizing flame. Due to competition from the oxy-acetylene and arc welding process, the oxy- hydrogen process is seldom used today for welding applications, but it

remains the preferred cutting tool in certain applications due to the resulting clean flame. Forming laboratory glass, polishing flexi-glass, and melting precious metals are common uses of Oxy-hydrogen flames today.

Operation

The apparatus used for oxy-hydrogen welding is similar to that of oxy-acetylene welding and consists primarily of the two steel cylinders: one for storing oxygen and the other for hydrogen at suitable pressures; a mixer and insulator of the gases, together with a regulator; high pressure reducing valves for each of the gases; armored hose; and the special torch.

Note: Since the arrangement for oxy-hydrogen welding is similar to that of oxy-acetylene welding process, except acetylene cylinder is replaced with hydrogen cylinder, Readers are advised to refer figure 5.6 for details regarding the equipment used.

In operation, suitable mixtures of hydrogen and oxygen gases are individually supplied and combined in the mixing chamber and carried to the torch tip through a single tube. This torch is initially cylindrical shaped where the gases enter, and later diminishes in size towards the tip and causes the gas to increase in speed up to the proper velocity. Theoretically, complete combustion of hydrogen requires a hydrogen-to-oxygen ratio of 2:1. When the mixture is ignited at the torch tip, combustion takes place resulting in a flame having temperature around 2500°C. The burning of H_2 and O_2 results in two by-products — energy release in the form of heat and water. The combustion reaction is as follows:

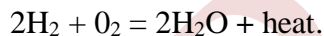

The resulting heat of the flame can be used to melt and fuse the metals to form a single piece of metal. Filler metal may be used as in case of oxy-acetylene process.

Advantages

- Process is simple and inexpensive.
- Results in clean flame, which is free from contaminants like carbon emitted from the combustion of ordinary hydrocarbon fuels
- Process is characterized by the absence of oxides formed on the surface of the weld.

Disadvantages

- Not suitable for welding high melting point alloys.
- Flame adjustment by varying gas proportions cannot be observed visibly. Gas proportions are fixed at particular values.
- The work should be heated first, in order to prevent chilling of the filling material, and the melt bar fused in to make the joint.

5.12 AIR-ACETYLENE WELDING

Air acetylene welding is a type of gas welding process in which the heat required for welding is obtained in the form of a flame, generated from the combustion of acetylene with air. The torch used in air acetylene welding process is similar in construction to a Bunsen burner as shown in figure 5.8. The acetylene gas which is stored in a cylinder under suitable pressure is made to flow into the welding torch through pressure regulator and hose. As the acetylene flows through the torch, it aspirates or draws appropriate amount of air from the atmosphere in order to obtain the oxygen necessary for combustion.

When the mixture at the torch tip is ignited with a spark, air enables the acetylene gas to burn completely to produce a clean, hot, and smokeless flame, which can be used for welding or any other applications. The use of this type of welding is limited, as the temperature attained is the lowest of all the gas welding processes. The process is used for lead welding, and low temperature brazing or soldering operations.

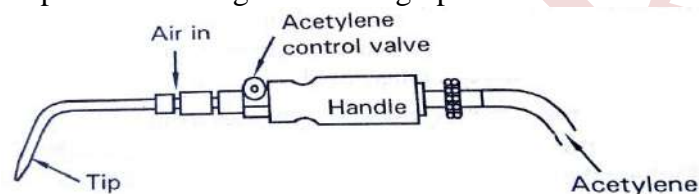

Figure 5.8 Air-acetylene torch

Welding Techniques

There are two techniques in gas welding process depending on the way in which the welding torch is used. They are:-

1. Leftward / Forward welding
2. Rightward / Backward welding

Leftward / Forward welding

The leftward method of welding is also known as forward welding. It is the oldest and most widely established method for the butt-welding of steel plates. Welding is commenced at the right hand edge of the plate and proceeds across the plane in a leftward direction, the blowpipe following the welding rod.

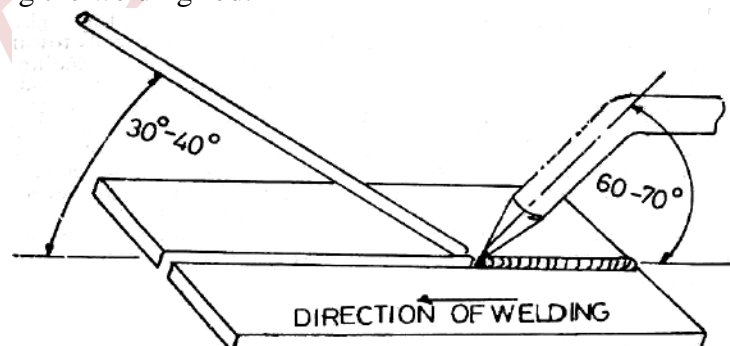

Rightward / backward welding

The rightward method of welding consists of commencing at the left-hand side of the plate and proceeding towards the right, the filler rod following the blowpipe (Refer Fig 2). It will be observed that the blowpipe point in the direction of the completed weld and that it moves regularly along the seam. There is no lateral movement of the blowpipe, rather the end of the filler rod describes a series of loops and doesn't progress steadily as in case of the leftward welding. It is not necessary to bevel the edges of the plate between 3/16" to 5/16" and even when a bevel is necessary the included angle should be only 60° and 80° as in the previous case.

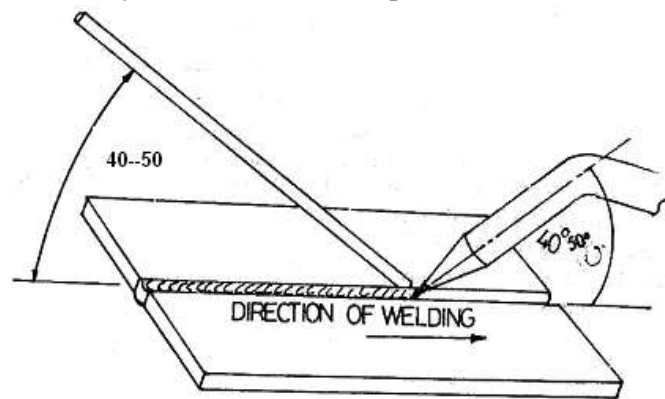

Difference between forward and backward welding

| Sl. No | Leftward/Forward welding | Sl. No | Rightward/Backward welding |
|--------|---|--------|---|
| 1 | Welding operation is done by working from right to left | 1 | Welding operation is done by working from left to right |
| 2 | The torch is held between the filler rod and the weld | 2 | The filler rod is held between weld and flame of torch |
| 3 | The angle of torch is between 60°-70° w.r.t. horizontal to ensure less obstruction to the operator. | 3 | The angle of torch is between 40°-50° w.r.t. horizontal to ensure less obstruction to the operator. |
| 4 | Due to oxidation of metal, the weld is not so strong, tough and dense. | 4 | Due to non oxidation of metal, the weld is quite strong, tough and dense. |
| 5 | Torch is given sideways movement for effective welding. | 5 | No need of sideways movement to torch for welding. |

| | | | |
|---|--|---|---|
| 6 | This type of welding is used for low melting metals. | 6 | This type of welding is normally used for thicker sections. |
| 7 | Acetylene requirement 100-120 lit/hr/mm. | 7 | Acetylene requirement 100-150 lit/hr/mm. |

5.13 GAS CUTTING

Gas cutting is a process of cutting metals by means of a flame generated by a combination of fuel gas and oxygen. Although a variety of fuel gases like acetylene, propane, MAPP (methyl-acetylenepropadiene), propylene and natural gas may be used, it is the acetylene gas that is commonly used as it produces a comparatively highest flame temperature, which is approximately around $3,160^{\circ}\text{C}$ that is capable of rapid piercing of the materials resulting in quality cutting edges with less heat affected zone and distortion. The process is often referred as oxy-acetylene cutting.

Oxy-acetylene Cutting Process

Oxy-acetylene cutting makes use of a torch as illustrated in figure 5.9. The cutting torch consists of three orifices for the separate flow paths as: pre-heat oxygen, cutting oxygen, and acetylene as shown in figure. The cutting oxygen jet comes from the central bigger orifice and is controlled by the valve lever or trigger.

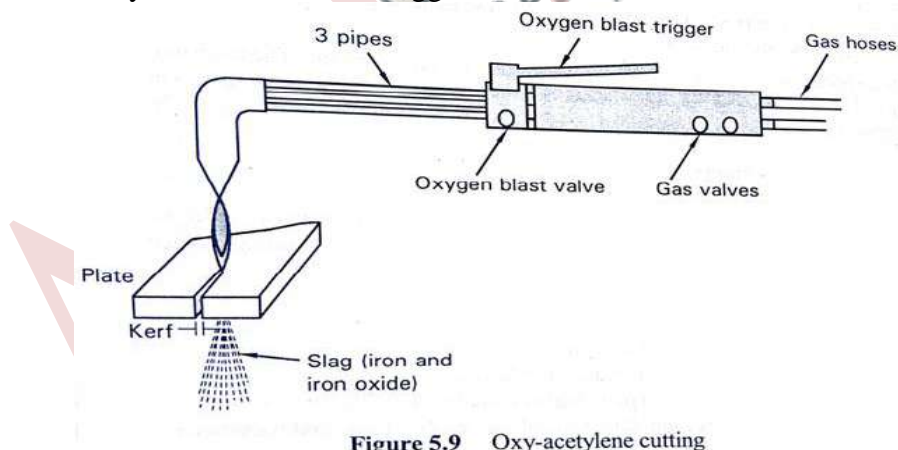

Figure 5.9 Oxy-acetylene cutting

Initially, oxygen and acetylene gas flowing in suitable proportions is mixed and ignited at the torch tip to preheat the workpiece metal to its ignition temperature but well below its melting point. At this point, a jet of pure oxygen released by the lever is directed into the preheated area resulting in an exothermic chemical reaction between the oxygen and the iron workpiece metal to form iron oxide or slag. Continued iron oxide formation requires large volumes of oxygen to be delivered to the cut zone at a controlled preset pressure. The jet of flowing oxygen blows away the slag enabling the jet to pierce through the material producing a narrow cut known as *kerf*

It must be noted that the heat produced by the iron oxide and its contact with the rest

of the material is the one that actively continues the cutting process. The torch only heats the metal to begin the process.

Advantages

- Process is simple, inexpensive, and faster than mechanical cutting methods.
- Any desired length and shape for assembly and other processing operations can be carried out effectively.
- The process can cut metals of thicknesses ranging from 0.5 mm to 250 mm.

Disadvantages

- The process is limited for cutting carbon steel (low, medium, and high) materials only.
- As compared to mechanical cutting, dimensional tolerances are poor.
- Working place needs to have adequate ventilation and proper fume control.
- Cutting operation is risky to the operator, due to the expelling/blowing of the red hot slag and other hot particles during cutting process.
- Cutting speed and quality depends on the purity of the oxygen stream. The torch nozzle must be designed so as to protect the oxygen stream from air entrapment. A decrease in purity of 1% will typically reduce the cutting speed by 25% and increase the gas consumption by 25%.

5.14 POWDER CUTTING

Powder cutting is an *oxygen cutting process* in which a suitable metal powder such as iron powder, or mixture of iron and aluminum powder, is injected into the cutting oxygen stream to assist the cutting action.

Need for Powder cutting

Materials such as stainless steel, cast iron, and non ferrous metals/alloys cannot be easily cut by oxy-acetylene process. Stainless steels react with the cutting oxygen stream to produce refractory (heat resistant) oxides having melting point higher than the parent material, which tend to prevent further cutting action by the oxygen. Other metals such as cast iron and the non ferrous metals either burn with less heat or they tend to cool the cutting zone to such an extent that it is difficult to start and maintain the cutting action. This barrier to cutting can be overcome by feeding finely divided iron-rich powder separately into the cutting zone in a gaseous medium. Combustion of the iron powder increases the reaction temperature and the fluidity of oxidation products, which in turn facilitates cutting action.

Principle of Powder Cutting Process

The powder cutting process makes use of the same equipment as that of the oxy-acetylene process with slight modifications.

The equipment consists of the following:

- Oxygen, acetylene cylinders, separate hose and regulators
- A hopper with control valve and regulator for automatic supply of iron powder
- Cutting torch consisting of orifices for separate flow path for pre-heat oxygen, acetylene and

cutting oxygen in addition to a special opening at its tip for supplying iron powder

Initially, oxygen and acetylene gas flowing in suitable proportions is mixed and ignited at the torch tip to preheat the workpiece metal to its ignition temperature. A finely divided 200-mesh iron powder from a hopper is injected in to the oxygen cutting flame through the torch tip. The powder is pre-heated as it passes through the pre-heat flames, and later bursts into a flame in the stream of cutting oxygen. The iron particles are rapidly oxidized resulting in a sudden increase of heat on the work metal surface. As a result of the intense heat supplement, the refractory oxides that form on the metal surface are melted and consequently flushed from the cutting area. This permits the cutting flame of the torch to come in contact with the iron of the metal and thus cutting proceeds without interference.

Advantages

- Process is suitable to cut materials having high affinity for oxygen at the cutting temperature.
- Results in high burning temperature offering excellent flow characteristics.

Disadvantages

- Working environment is polluted due to smoke generated.
- Use of finely divided iron powder adds cost to the process.

5.15 INTRODUCTION TO SOLDERING

Soldering is a group of joining process used for joining similar or dissimilar metals by means of a *filler metal* whose melting temperature is *below* 450°C. The filler metal usually called *solder* is an alloy of tin and lead in various proportions. The flow of molten solder into the gap between the two workpieces is by the *capillary action**. The solder cools down and solidifies forming a joint. The base metals are not fused in the process.

5.15.1 Types of Solder

A solder is an alloy, which melts at low temperatures. There are two types of solder:

(i) Soft solder

- These are alloys of tin and lead. *Example* Lead = 37 % and Tin = 63 %.
- They have low melting points ranging from 150°C — 190°C.
- A very small amount of antimony, usually less than 0.5% is sometimes added to increase the mechanical properties of the solder. But, its addition should be controlled, otherwise which might impair soldering characteristics.
- Soft solders are used in those applications, where the joint is not subjected to heavy loads and high temperatures.

(ii) Hard solder

- Silver alloyed with lead (*Example* lead = 97.5 % and silver = 2.5 %) or silver alloyed with copper and zinc (*Example* Silver = 50 %, copper = 34 %, and zinc = 16 %) are called hard solder.

* *During soldering, the molten solder is introduced at the joint. A pulling force draws the molten filler between the surfaces of the parent (base) metals. This is known as capillary action.*

- Melting point of hard solder ranges from 300 - 600°C.
- Used to make strong joints that can resist high temperatures.

5.15.2 Surface cleaning and Soldering Flux

Capillary action (wettability) is achieved by proper *surface preparation* and *use* of suitable flux for wetting and cleaning the surfaces to be bonded.

Surface preparation includes thoroughly cleaning the workpiece surfaces to remove contaminants like oil, rust, scale, paint, and other impurities either mechanically (wire brushing, abrasion techniques etc.) or chemically (soaking, cleaning or acid etching). Once the contaminants are removed, the next step is to select a suitable flux.

A soldering flux is a substance, either in a liquid or semi-liquid state that melts during the preheating stage and spreads over the joint area, wetting it and protecting the surface from oxidation. The flux also cleans the surface, dissolving the metal oxides.

Different types of flux include rosin-alcohol, zinc chloride, aniline phosphate etc. The flux maybe applied onto the metal surface by brushing, dipping, spraying, or by any other methods.

5.16 TYPES OF SOLDERING

Soldering methods are classified based on the mode of heat application. The heat applied should be such that it should melt the solder and permit the molten solder to flow quickly into the joint. Various soldering methods include:

- Soldering iron method
- Torch method
- Induction method
- Wave method
- Resistance method
- Ultrasonic method etc.

(a) Soldering iron method

It is the most common and widely used method of soldering. The tool used in this method is a *soldering iron* with a copper coated tip (due to good conductor of heat), which may be heated electrically, or by oil/gas flame. The tip of the soldering iron stores and conducts heat from the heat source to the components being joined. Figure 5.10 shows the soldering process.

The surface of the workpiece is cleaned thoroughly to remove any contaminants. Flux is applied at the joint. The soldering iron is heated to a suitable temperature and a little solder

is melted at the tip of the soldering iron. The tip of the soldering iron, called the *bit*, is brought at the joint and the molten solder is deposited. The molten solder flows into the joint by the capillary force. The solder cools down and solidifies forming a joint. The joint is cleaned to remove flux residues in order to prevent corrosion.

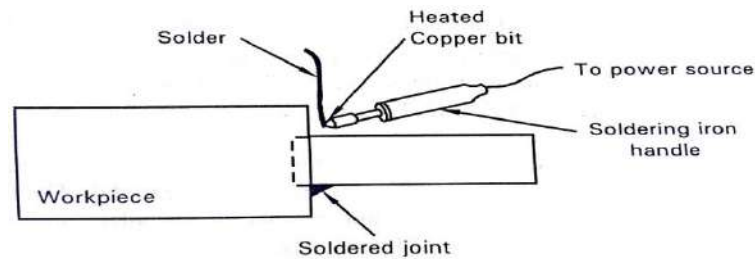

Figure 5.10 Soldering

Soldering irons come with various ratings from 15 W to over 100W. The advantage of using high Wattage iron is that, heat can flow quickly into the joint, so it can be rapidly made. Small irons are used to make joints for small electronic components only, as they might get damaged due to excess heat.

(b) Torch soldering

Torch soldering utilizes the heat of a flame issued from a oxy-fuel gas torch. The *torch* mixes a fuel gas like acetylene with oxygen in suitable proportions, and burn the mixture at its tip. The flame generated at the torch tip is directed at the workpieces with a flux applied on their surfaces. When the workpieces are heated to a suitable temperature, the solder is fed into the joint region to melt and flow into the gap between the two workpieces. The solder cools down and solidifies forming a joint.

(c) Wave soldering

Wave soldering is a very popular approach for soldering through-hole components on printed circuit boards. This method uses a tank full with a molten solder. The solder is pumped, and its flow forms a wave of a predetermined height. The printed circuit boards pass over the wave touching it with their lower sides.

5.16.1 Advantages and disadvantages of soldering

Advantages

- Low power requirements.
- Low temperature process. Hence, no thermal distortions and residual stresses in the joint parts.
- Dissimilar parts can be easily joined.
- Thin parts can be joined.

Disadvantages

- Flux residues should be removed after soldering, otherwise which causes corrosion.
- Thick parts cannot be efficiently joined.
- Soldered joints cannot be used in high temperature applications.
- Strength of joint is low.

5.17 BRAZING

Brazing is a method of joining similar or dissimilar metals by means of a filler metal whose melting temperature is above 450°C, but below the melting point of the base metal. The filler metal called *speller* is a non-ferrous metal or alloy. Copper and copper alloys, silver and silver alloys, and aluminum alloys are the most commonly used filler metals.

The flow of molten filler material into the gap between the two workpieces is driven by the capillary force. The filler material cools down and solidifies forming a strong joint. The base metals are not fused in the process.

Flux used in brazing

Flux performs its usual function as in soldering, i.e., it melts during the preheating stage and spreads over the joint area, wetting it and protecting the surface from oxidation. It also cleans the surface, dissolving the metal oxides.

The flux used in brazing is available in powder, liquid, and paste form. One method of applying the flux in powdered form is to dip the heated end of the filler rod into the container of the powdered flux, and allowing the flux to stick to the filler rod. Another method is to heat the base metal slightly and sprinkle the powdered flux over the joint, allowing the flux to partly melt and stick to the base metal. Sometimes, it is desirable to mix powdered flux with clean water (distilled water) to form a paste.

Flux in either the paste or liquid form can be applied with a brush to the joint. Better results occur when the filler metal is also given a coat. The most common type of flux used is borax, or a mixture of borax with other chemicals. Some of the commercial fluxes contain small amounts of phosphorous and halogen salts of iodine, bromine, fluorine, chlorine, or astatine. When a prepared flux is not available, a mixture of 12 parts of borax and 1 part boric acid may be used.

5.18 TYPES OF BRAZING

Brazing is similar to soldering, except, the difference is in the melting point of the filler alloy. Brazing methods are classified based on the mode of application of heat. They are:

- Torch brazing
- Furnace brazing
- Dip brazing
- Resistance brazing
- Induction brazing

- Vacuum brazing etc.

(a) Torch brazing

Torch brazing is a brazing process in which the two metals are joined by the heat obtained with a gas flame, and by using a non-ferrous filler metal having a melting temperature of above 450°C, but below the melting temperature of the base metal. Figure 5.11 shows the brazing process.

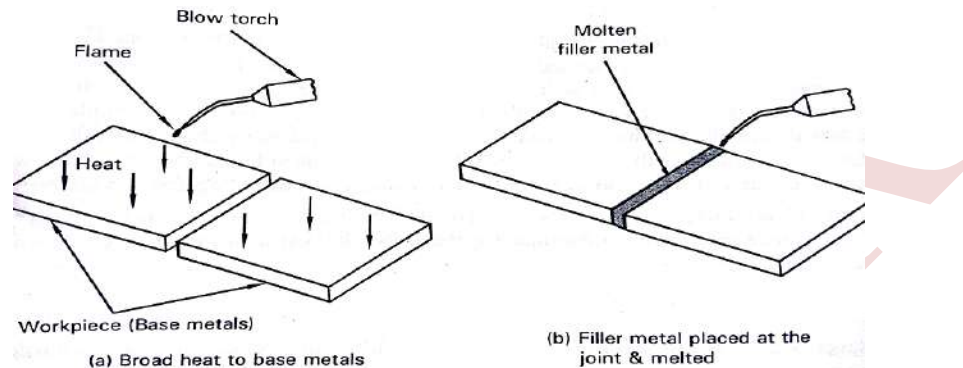

Figure 5.11 Brazing

In operation, the surfaces to be joined are cleaned thoroughly in order to remove dirt, grease and other oxides. After cleaning, flux is applied at the joint. The base metals are broadly heated by an oxy-acetylene welding torch as shown in figure 5.11(a). The filler metal is then placed at the joint and is heated with a carburizing flame. The filler metal melts and flows through the joint by capillary action. Refer figure 5.11(b). The workpiece is allowed to cool for some time. The joint is cleaned to remove flux residues in order to prevent corrosion.

(b) Furnace brazing

Furnace brazing is a brazing process in which bonding is produced by the furnace heat and a nonferrous filler metal having a melting temperature of above 450°C, but below the melting temperature of the base metal. The filler metal is distributed in the joint by capillary attraction.

Furnace brazing is suited for fabricating complete brazements, and does not require a highly skilled operator. Pre-fluxed or pre-cleaned parts with filler metal pre-placed at the joints are heated in furnaces. Brazing can be done in an *air furnace* with a flux, though a protective atmosphere usually is needed. The type of atmosphere required depends on the materials being brazed and the filler metals being used. Base metals with readily reducible oxides can be brazed in an atmosphere of combusted natural gas or cracked ammonia. Dry hydrogen, a powerful reducing agent can be used for brazing most stainless steels and many nickel, cobalt and iron-base alloys.

(c) Dip brazing

Dip brazing is one of the oldest brazing processes. The materials to be joined are immersed in a bath of hot liquid, which is either a molten flux or a molten filler metal that usually contains a layer of flux to prevent oxidation. Dip brazing is used on aluminum

assemblies, since the temperature of the molten bath can be controlled.

In aluminum dip brazing the filler metal is basically 88% aluminum and 12% silicon. The parts to be brazed after being chemically cleaned, are assembled with the filler metal preplaced as near the joints as possible. The assembly is then preheated in an air furnace to 550°C to ensure uniform temperature of dissimilar masses in the assembly. The part is then immersed in a molten salt bath. These salts are actually aluminum brazing flux. The bath is maintained at about 590-600°C in a salt bath furnace. As the assembly is immersed or dipped, the molten flux comes in contact with all internal and external surfaces simultaneously. This liquid heat is extremely fast and uniform.

Since the bath is a flux, complete bonding on oxide-free surfaces assures unusually high quality joints. The time of immersion is determined by the mass to be heated, but never exceeds above two minutes in duration.

(d) Resistance brazing

Resistance brazing is suited for special joints where heat must be restricted to a localized area without overheating surrounding parts. The heat required for brazing is produced due to the electrical resistance offered by the joint members to the flow of current through them.

(e) Induction brazing

Induction brazing utilizes alternating electromagnetic field of high frequency for heating the workpieces together with the flux and the filler metal placed in the joint region. The technique is used only in those applications, where the entire assembly would be adversely affected by heat. Since the workpieces are heated selectively by the coil, induction brazing reduces unwanted part distortion.

Induction heating brings the joint rapidly to brazing temperature.

Advantages

- Much heat is not involved in the process. Hence, low thermal distortions and residual stresses in the joints.
- Easily automated process.
- Dissimilar parts can be joined.

Disadvantages

- Flux residues must be removed after brazing, otherwise which may cause corrosion.
- Large and thick sections cannot be brazed efficiently.
- Relatively expensive filler materials.

5.18.2 Comparison between Brazing and Soldering

Table 5.1 shows a brief comparison between brazing and soldering.

| Sl. No. | Brazing | Soldering |
|---------|---|--|
| 1. | Filler metal used in Brazing is called <i>spelter</i> | Filler metal is called <i>solder</i> |
| 2. | Melting point of <i>filler metal</i> is above 450 °C but below the melting point of the work piece metal. | Melting point of <i>filler metal</i> is below 450 °C |
| 3. | Stronger joints can be obtained in brazing | Strength of the joint is comparatively low. |
| 4. | Brazed joints resist corrosion. | Soldered joints do not resist corrosion to the same extent as that of brazed joints. |
| 5. | Brazing is slightly costlier | Comparatively cheaper |

Table 5.1 Comparison between brazing and soldering

5.19 INSPECTION METHODS

Inspection is an art or process, which involves checking dimensions, observation of correctness of operations, and examining the presence and/or the extent of imperfections in a fabricated part to ensure whether the part conforms to the design requirements. The different inspection methods are discussed briefly below.

(a) Dimensional Inspection

In this method, micrometers, automatic gauges etc., are used to check the dimensions of parts against the drawings.

(b) Metallurgical Inspection

Specific equipments like disc sectioning machine, specimen mounting press, grinding, polishing turntables, some acid etching capabilities, and an optical metallurgical microscope with magnification capacity of up to $x500$ at least is required for metallurgical inspection. Weld bead shapes, discontinuities, metallographic phases in different areas of the weld and cast materials can be obtained with this method of inspection.

(c) Mechanical Inspection

Mechanical inspection is also called *destructive inspection*, because the parts to be

inspected are partly or completely damaged during inspection. Various properties of a material like tensile strength, compression strength, shear strength, hardness, impact strength etc., can be evaluated from this method of inspection.

(d) Non-destructive Inspection

Non-destructive inspection involves assessing the soundness and acceptability of the part without destroying or altering the structure of the fabricated part. Internal defects like cracks, flaws, blow holes, etc., can be effectively determined by this method. The various tests involved in this method include:

- Visual inspection
- Magnetic particle inspection
- Fluorescent particle test
- Ultrasonic inspection.
- Radiography inspection
- Eddy current inspection
- Holographic inspection etc.

5.20 VISUAL INSPECTION

Visual inspection is the most widely used method of all the non-destructive tests. It is a simple test that consumes less time, but is useful only to detect the presence of defects on the *surface of the fabricated part*.

The part is illuminated with light and then examined with naked eyes, or sometimes a magnifying lens or a low power microscope may be used as an aid to the eye. Visual inspection is often overlooked, but it provides a wealth of information about surface defects like cracks, porosity, fusion, edge melt and incomplete penetration. A weld that passes a visual inspection has a much higher probability of passing further non-destructive evaluation tests.

5.21 MAGNETIC PARTICLE INSPECTION

Magnetic particle inspection method uses *magnetic fields* and *small magnetic particles* to detect surface defects or near-surface defects *in ferrous materials*. Figure 5.12 shows the principle of magnetic particle inspection. The various steps involved in the inspection process include.

(a) Magnetizing the part

The part to be inspected is cleaned thoroughly from dirt, rust and oxides, and held between two copper dams as shown in figure 5.12(a). When a high current is passed through the part, magnetic flux is produced at right angles to the flow of current. If the material is sound or

detect free, most of the magnetic flux is concentrated below the materials surface. Refer figure 5.12(b). However, when a defect/discontinuity is present in the part, the magnetic flux get diverted and leak through the surface of the part creating magnetic poles or points of attraction. The crack edge becomes magnetic attractive poles: *north* and *south* as shown in figure 5.12(c).

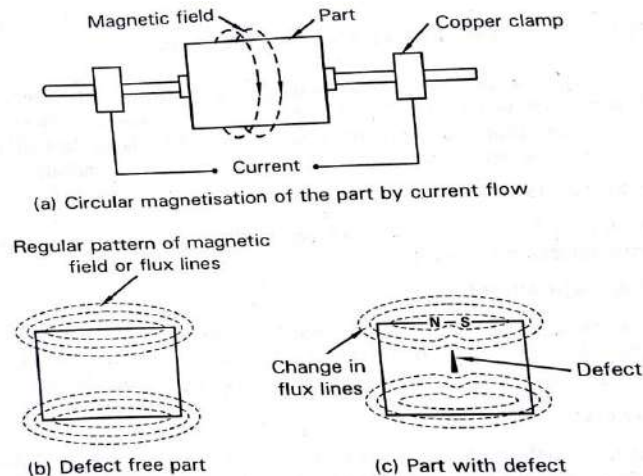

Figure 5.12 Magnetic particle inspection

(b) Detection of defect

The presence of the leakage field and therefore the presence of the discontinuity is detected by dusting finely divided iron oxide particles on to the surface, so that the particles cling to the leakage area indicating the location of discontinuity.

The part is demagnetized and cleaned by suitable process.

Advantages

- Easy, fast, economical and reliable way to locate discontinuities.
- * *Magnetic particles may be coloured with red or black, and are usually applied as suspension in water or paraffin. This enables the particles to flow over the surface and to migrate to any flaws/discontinuities.*
- Even non-metallic inclusions close to the surface can be detected.
- Can be automated.

Disadvantages

- Restricted to ferromagnetic materials.
- Restricted to surface or near-surface flaws.
- Skilled operator is required for efficient inspection
- Parts should be demagnetized and cleaned prior to use.

5.22 FLUORESCENT PENETRANT INSPECTION

Fluorescent penetrant method of inspection is used for testing parts made with ferrous and nonferrous materials. The process is preferred for parts with discontinuities like cracks, porosity, shrinkage etc. that are clear and open to the surface. Figure 5.13 shows the steps involved in the inspection process. The various steps involved in the inspection process include:

(a) Surface preparation

The part to be inspected is cleaned thoroughly to remove dirt, oxide and other impurities for efficient detection of the defect. Refer 5.13(a).

(b) Application of penetrant

A coloured (fluorescent) penetrant liquid is applied to the surface of the part being tested by either dipping, brushing or spraying method. After sufficient time is allowed, the penetrant easily enters into the flaw due to capillary action and low surface tension. Refer figure 5.13(b).

(c) Removing excess penetrant

The excess penetrant on the part surface is washed away with water or a solvent, and then dried with air. Refer figure 5.13(c). Care should be taken not to remove any penetrant from the flaw.

(d) Developer application

A developer in the form of dry powder (*Example* CaCO_3), or suspension of powder in liquid (alcohol or spirit) is applied on the surface. The developer acts like a blotter and draws the penetrant out of the flaw. Refer figure 5.13(d).

(e) Inspection

The part is inspected in a dark enclosure under ultraviolet or black light. The blotted out fluorescent particles will give a visible glow under ultraviolet light revealing the presence of the defect.

Fluorescent penetrant test is very effective for machined and finished parts.

Advantages

- Simple, easy to use, and also low cost.
- No need for skilled inspector.
- Useful for both ferrous and non-ferrous materials including glass and ceramics.
- Flaws are clearly visible due to the bright fluorescent against a dark background.

Disadvantages

- Only cracks open to the surface can be inspected.
- Surfaces of parts should be extensively cleaned before testing.

- Penetrant dyes stain clothes and skin while in use.

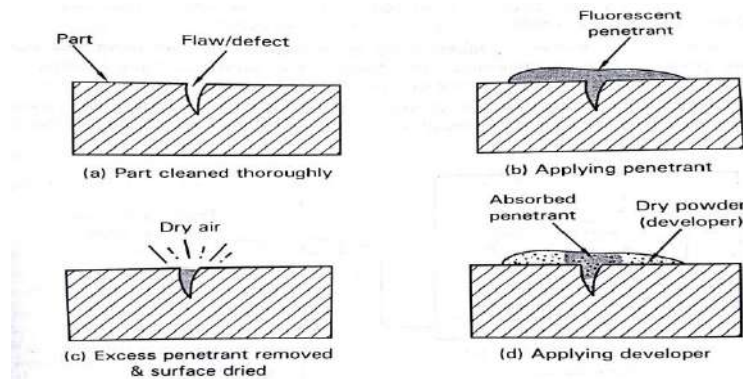

Figure 5.13 Fluorescent penetrant inspection

5.23 ULTRASONIC INSPECTION

Ultrasonic inspection is used to detect surface and sub-surface defects in both ferrous and nonferrous materials. Figure 5.14 shows the simplified diagram of the testing procedure.

Steps involved in the inspection process

- The surface of the workpiece to be tested is cleaned thoroughly to remove dirt and other oxides. The transducer placed above the workpiece converts electrical energy into mechanical vibrations (sound energy), and vice-versa.
- The sound energy from the transducer propagates through the couplant and strikes the upper surface of the workpiece metal in the form of waves.
- The waves from the upper surface travel and strike the other end surface of the workpiece and will be reflected back to the transducer. In simple words, the transducer sends the waves and also receives the reflected waves.
- The reflected waves are transformed into electrical signals by the transducer and are displayed on the CRO (cathode ray oscilloscope) screen as a sharp peak (point A).
- When the propagating wave strikes a defect, the wave get reflected in the mid-way, back to the transducer, and as a result, an echo is displayed at point B on the CRO screen before another echo given by the wave at point C striking at the far end of the job.
- Thus, imperfections or other conditions in the space between the transmitter and receiver reduce the amount of sound transmitted, thus revealing their presence. The

echo at point B is an indication of the defect present in the workpiece.

- g) Ultrasonic inspection not only helps to identify the defect, but also gives information about the location, size, and distance from the surface of the workpiece, orientation and other features of the defect.

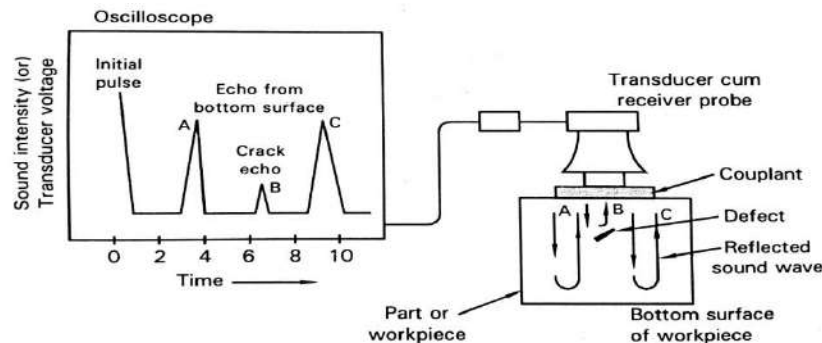

Figure 5.14 Ultrasonic inspection

Advantages

- Method is fast and allows detection of even small flaws deep in the part. Lengths up to 30 feet can be tested.
- Instant test results.
- Can estimate size, shape, orientation, and other features of the defect.
- Only one surface of the workpiece is sufficient for inspection.
- Equipment is portable.
- Greater accuracy compared to other non-destructive inspection methods.

Disadvantages

- Requires skilled inspectors with extensive technical knowledge.
- Parts that are rough, very small, thin or non-homogenous are difficult to inspect.
- Extensive surface preparation of workpiece is required.
- Cast iron and other coarse grained materials are difficult to inspect due to low sound transmission and high signal noise.

*The couplant is an oil film maintained between the transducer and the workpiece to ensure proper contact between them and better transmission of waves into the workpiece material.

5.24 RADIOGRAPHY INSPECTION

Radiography inspection, also known as X-ray inspection is one of the oldest and widely used method for detecting *sub-surface cracks* and inclusions in both ferrous and non-ferrous materials.

Description and Operation

- a) The equipment consists of an evacuated bulb inside which there is a *filament* that acts as cathode, and the *target* as anode.

- b) When the filament is heated by passing current, it emits electrons, which in turn are accelerated towards the *target* due to the high potential difference.
- c) The electrons strike the *target* and are suddenly stopped; a part of their kinetic energy is converted to energy of radiation or x-rays.
- d) The x-rays then deviate to pass through the workpiece material containing a defect.
- e) Since the defect possesses low density, they transmit x-rays better than the adjacent sound metal that possesses high density.
- f) The x-rays after passing through the workpiece are allowed to fall on a light-sensitive film placed at a suitable distance behind the workpiece.
- g) Interpretation of x-ray film is only about distinguishing between areas of film blackness. Defects in the form of cracks or voids are recorded as blackened areas on the film compared to the adjacent portion of less black areas.

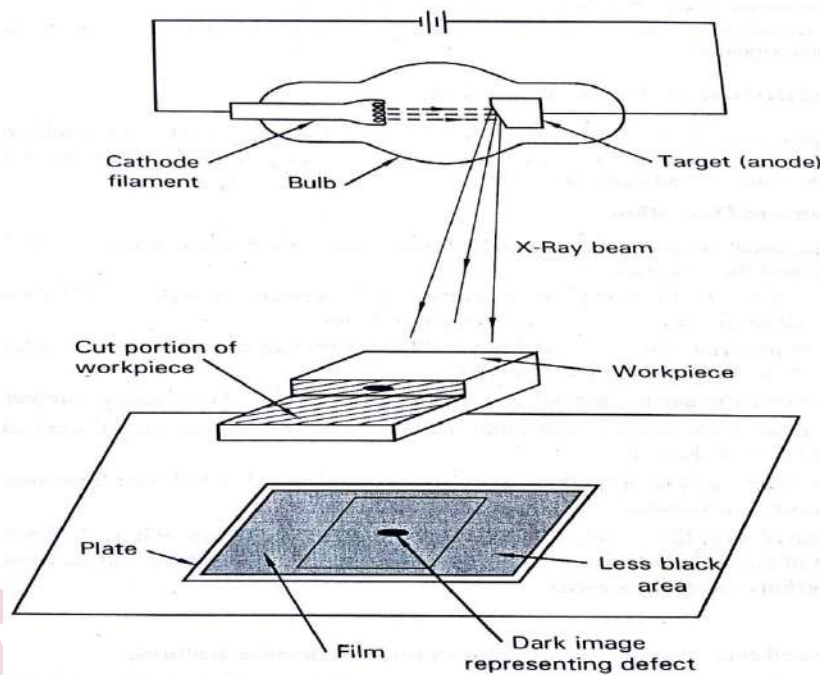

Figure 5.15 Radiography inspection

Advantages

- Image of the defect is obtained, which helps to study its detailed features.
- Widely accepted inspection method. Can determine any type of defect in a material.
- Parts to be inspected need not be disassembled. This reduces labour and time.

Disadvantages

- Expensive method compared to other non-destructive methods. Involves high cost in equipment, film and processing.
- Film processing requires time. Hence, defect cannot be analyzed on the spot.

- Skilled inspector is required to analyze defect.
- Not suitable for surface defects.
- No indication about the depth of the defect.

5.25 EDDY CURRENT INSPECTION

Eddy current inspection uses the principle of *electromagnetism* as the basis for conducting examinations. When a circular coil (also called probe) carrying alternating current is brought *near* the workpiece metal, the magnetic field of the coil will induce circulating (eddy) currents in the workpiece surface. Refer figure 5.16(a).

The magnitude and phase of the eddy currents will affect the loading on the coil, and thus its impedance. For example, when the workpiece metal is defect free, the eddy currents will be uniform and consistent (circular shape) as shown in figure 5.16(a). However, if there is some defect such as a crack in the workpiece, the eddy currents will be disturbed from their normal circular pattern as shown in figure 5.16(b). This will reduce the eddy current flow, thereby decreasing the loading on the coil and increasing its effective impedance.

The resulting change in phase and magnitude of the eddy currents can be displayed on a cathode ray tube (CRT) type displays. This gives the operator, the ability to identify defect conditions in the workpiece. The size of the defect can also be determined to a certain extent (by the absence of metal).

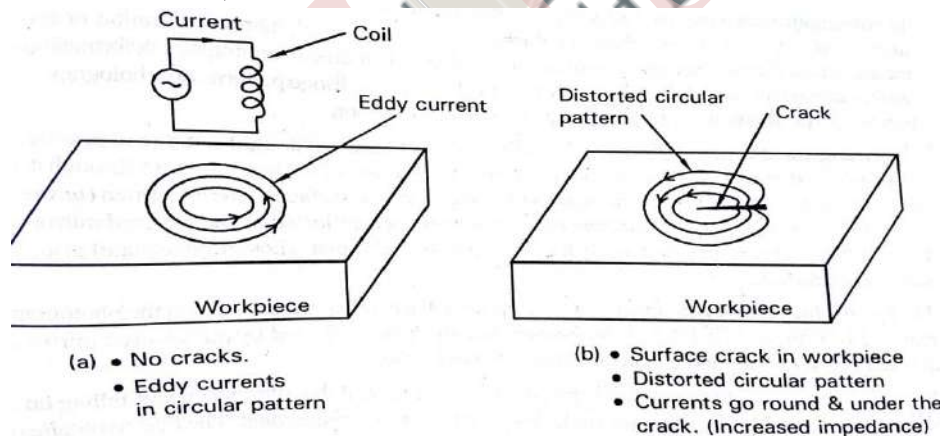

Figure 5.16 Eddy current inspection

Advantages

- One of the major advantage of this method is that, a variety of inspections and measurements can be performed like defect detection, hardness, material thickness measurements, coating thickness measurements, conductivity measurement for heat damage detection, case depth determination, heat treatment monitoring etc.
- Test probe or coil used need not contact the part to be inspected.
- Very sensitive to small cracks.

- Inspection gives immediate results.
- Equipment is portable.

Disadvantages

- Only conductive materials can be inspected.
 - Surface must be accessible to probe.
 - Skill and training required is more extensive than other techniques.
 - Surface finish and roughness may interfere.
 - Depth of penetration is limited.
- Cracks lying parallel to the current path are undetectable.

5.26 HOLOGRAPHY INSPECTION

In holography technique, the test sample is interferometrically compared in two different states: *unstressed* and *stressed state*. Stressing can be done by mechanical, thermal, vibration, or any other means. A flaw can be detected, if by stressing the object, it creates an anomalous deformation of the surface around the flaw. The deformations are made visible as fringe patterns on a holographic film. Figure 5.17(a) shows the arrangement for holography inspection.

The arrangement consists of a *laser* from which a beam of coherent light is made to pass through a half-silvered mirror. The half-silvered mirror allows *a part* of the beam to pass through it, then through the lens which diverge the beam before falling on the surface of the specimen (*unstressed state*) to be inspected. The *remaining part* of the beam gets reflected by the silvered mirror, pass through the diverging lens, and finally fall on the photographic plate (holographic plate) placed in a suitable orientation.

The beam which falls on the specimen to be inspected gets reflected and falls on the photographic plate. This beam is called the *object beam*, while the beam reflected by the silvered mirror and incident on the photographic plate is called *reference beam*.

The interference effect of the two beams; the object beam and the reference beam falling on the photosensitive surface results in the recording of interference fringes on it. The film so obtained is called *hologram*.

Reconstruction of Image

The hologram is fixed in the same place where it was a photographic plate during the first recording stage. The specimen and the source are also positioned in their same places. The specimen is now subjected to the required stress. Stressing can be done by mechanical, thermal, vibration or any other means. The procedure for recording the hologram is repeated.

The light (reference beam) which falls directly on the hologram (reference beam) leads to reconstruction of the image of the object in the unstressed state. This light interferes with the light reflected from the stressed object and produces bright and dark fringe pattern

as shown in figure 5.17(b).

The resulting interference pattern contours the deformation undergone by the specimen in between the two recordings. Surface as well as sub-surface defects show distortions in the otherwise uniform pattern. In addition, the characteristics of the component, such as vibration modes, mechanical properties, residual stress etc., can be identified through holographic inspection.

Holographic interferometry possesses high sensitivity to surface displacements and allows visual monitoring of interference fringe patterns that characterize surface deformation and the presence of non-contact areas in objects of complex shape.

Holographic technique is widely applied in aerospace to find impact damage, corrosion, delamination, debonds, abradable seals, brazed honeycomb seals, and cracks in high performance composite aircraft parts as well as turbine blades, solid propellant rocket, motor casings, tyres and air foils. With the advent of using mega-pixels CCD* cameras and digital image processing, holography technique offers tremendous flexibility and real-time visualization. Furthermore, image-processing schemes can provide computerized analysis of patterns for automated defect detection and analysis.

Advantages

- Automated process.
- Suitable for surface as well as sub-surface defects.
- High quality images can be obtained for thorough inspection.
- Used to detect wide range of abnormalities other than defects in the workpiece.

Disadvantages

- High equipment cost.
- Skilled operator is required.
- High-resolution films are necessity for holograms. However, use of CCD cameras allows the results to be viewed on a video monitor. But, the process is still expensive.

Optical holography for surface deformations

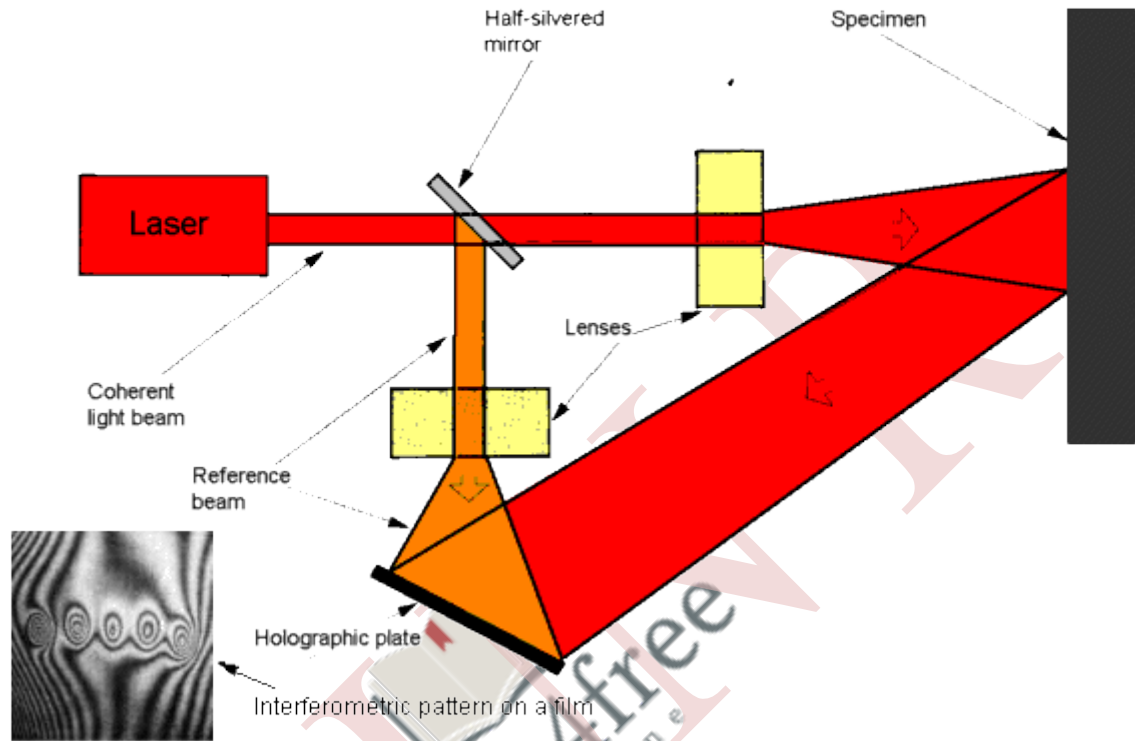

Figure 5.17 Holography Inspection